

Oil and Gas Pipeline Design, Maintenance and Repair

Dr. Abdel-Alim Hashem

Professor of Petroleum Engineering

Mining, Petroleum & Metallurgical Eng. Dept.

Faculty of Engineering – Cairo University

aelsayed@mail.eng.cu.edu.eg

ahshem2000@yahoo.com

Part 12: LEAK DETECTION AND SCADA SYSTEM

Content

- **Methods of Detecting a Leak.**
- **Leak Detection Instruments.**
- **Description of Leak Detection Equipment**
- **Recommended Method for Surface Gas Detection Survey with FI Unit.**
- **Odorants**
- **Follow-up Inspection.**
- **Leak Classification and Action Criteria.**

Methods of Detecting a Leak

- Odor.
- Vegetation.
- Insects (flies, roaches, spiders).
- Fungus-like Growth.
- Sound.
- Unaccounted for Gas.
- Soap Solutions.
- Leak Detection Instruments.

1.Odor

- Gas odor is a common and effective indication of a leak
- Gas is intentionally odorized so that the average person can perceive it at a concentration well below the explosive range .
- Odorant concentration is generally between 0.5 to 1.0 percent by volume or as local applicable codes dictate .**A report of gas odor should be investigated immediately .**
- If a leak is found, the migration pattern of the gas should be determined .
- If an immediate hazard is determined to exist, the hazard potential should be eliminated and the leak repaired immediately .

2. Vegetation

- Vegetation in an area of gas leakage may improve or deteriorate, depending on:-
 - 1- The soil.
 - 2- The type of vegetation.
 - 3- The environment.
 - 4- The climate.
 - 5- The volume and duration of the leak.
- Changes in vegetation may indicate slow below ground leaks.
- A vegetation survey by itself is not an acceptable method of complying with the pipeline safety regulations.
- Leak surveys should be conducted with leak detection equipment.

3. Insects (flies, roaches, spiders).

- Insects migrate to points or areas of leakage due to microbial breakdown of some components of gas.
- Some insects like the smell of the gas odorant.
- Heavy insect activity, particularly near the riser, the gas meter, or the regulator, can sometimes indicate a gas leak.

4. Fungus-like Growth.

- Such growth in valve boxes, manholes, etc., may indicate gas leakage.
- These fungi grow best where there is a lack of oxygen, such as in a gas leak area.
- The color of the growth is generally white or grayish-white similar to a coating of frost.
- All such indications should be investigated with a leak detection instrument.
- Personnel should never enter manholes or other confined spaces without first testing oxygen levels and gas concentrations.
- Check **O**ccupational **S**afety and **H**ealth **A**dministration (**OSHA**) regulations concerning confined space entry for further details on this subject.

5.Sound.

- Listen for leaks.
- A hissing sound almost at:
 - 1- A bad connection.
 - 2- A fractured pipe.
 - 3- A corrosion pit is the usual indication of a gas leak.

6. Unaccounted for Gas.

- A possible leak is indicated when an off-peak reading of a master meter.
- Periodic off-peak checks can be averaged to provide data for comparison in future checks.
- This method may indicate a leak on the system, but will not provide a location for the leak.
- It is also most effective if consumption figures are known for a time period before the leak(s) occurred.

7. Soap Solutions.

- A soap solution can pinpoint the location of a leak on:
 - 1-an exposed pipe.
 - 2- On the riser.
 - 3- On the meter.
- The solution is brushed or sprayed on and the location of bubbling indicates leakage.
- When excavating underground piping to investigate a suspected leak location, the pipe should be brushed and completely clean.
- Many leaks are found on the bottom of the pipe.

- A mirror may be used to observe the underside of the pipe.

Leak Detection Instruments

Leak Detection Instruments.

- Gas leak indicators are sophisticated instruments that require regular care, maintenance, and calibration, and should be used by trained personnel.
- Two types are commonly used by the gas industry for surveying and pinpointing leak:
 - Bead sensor type detector.
 - **Combustible Gas Indicator (CGI).**
 - **Flame Ionization (FI)** gas detector.
 - PD (Personal Detector) Short Locator.

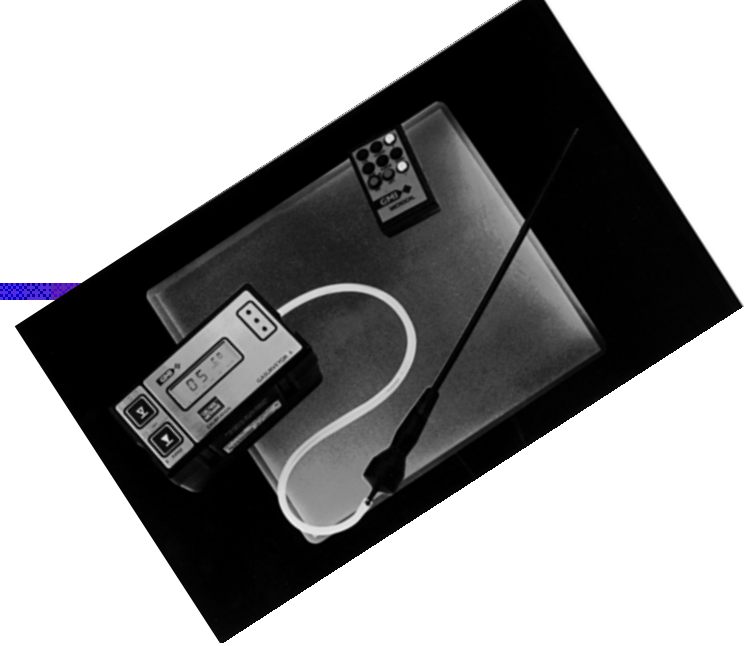

Leak Detection Equipment

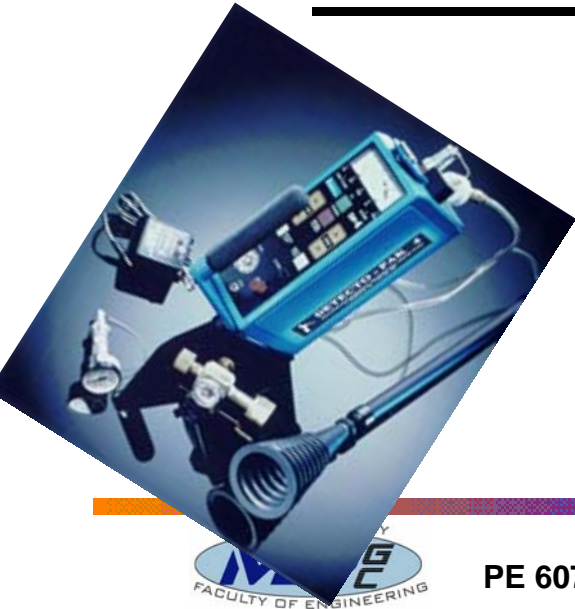

Description of Leak Detection Equipment

Bead sensor type detector

- Is most often used for inspecting exposed piping and appliances to pinpoint leaks on those facilities.
- Bead sensor instruments are not generally used for leak surveys of underground piping.

Combustible Gas Indicator (CGI).

- The CGI was designed primarily for use in a confined space.
- The CGI (Figure IV-3a & IV-3 b) consists of:
 - Meter.
 - Probe.
 - Aspirator bulb.
- The bulb is pumped by hand to bring a sample of air into the probe and the instrument.
- The CGI is not suitable for above ground surveys.
- These instruments must be calibrated for the type of gas in the system.
- The CGI should be calibrated for natural gas for use on a natural gas system.

Combustible Gas Indicator (CGI).

Analogue Driven



Figure IV-3a

Combustible Gas Indicator (CGI)

Digital Readouts.

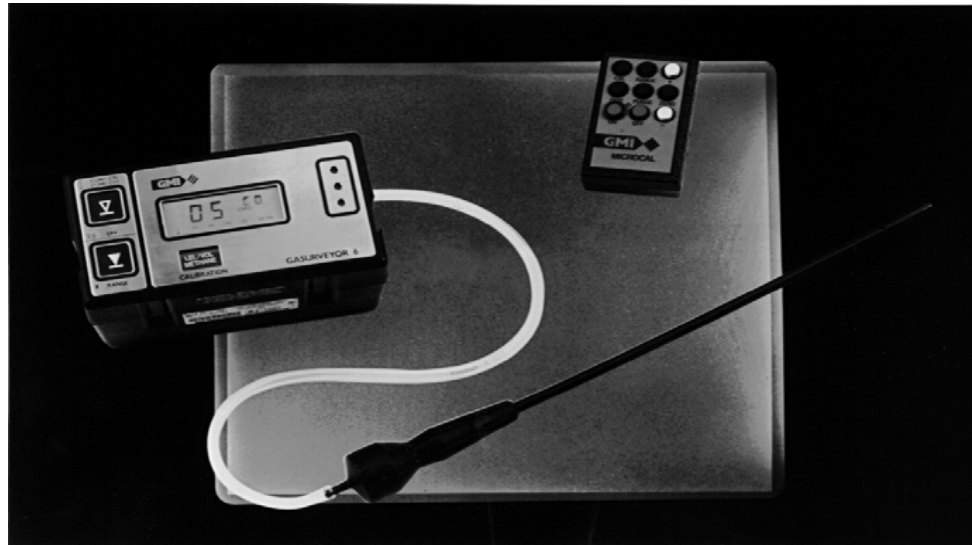
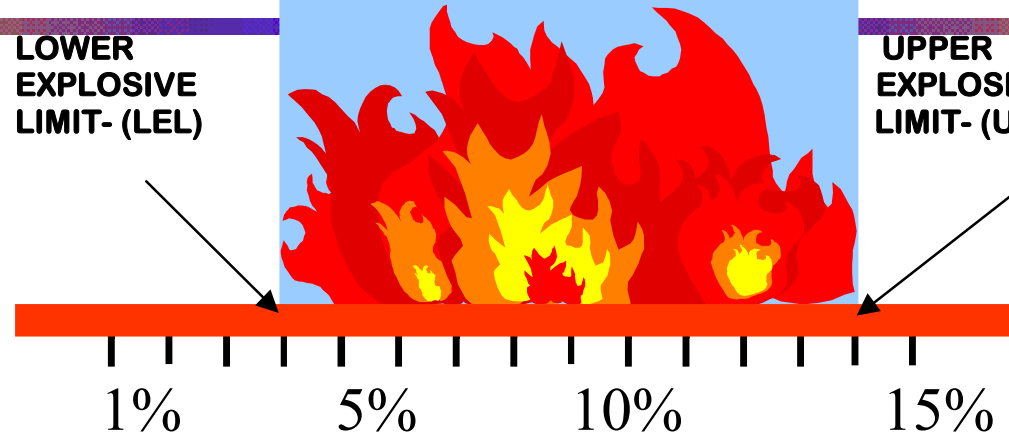

Figure IV-3b

LIMITS OF FLAMMABILITY

LOWER
EXPLOSIVE
LIMIT- (LEL)

UPPER
EXPLOSIVE
LIMIT- (UEL)



NATURAL GAS-IN-AIR MIXTURE

Figure IV-4

- 1- This is an illustration of the lower and upper explosive limits for natural gas
- 2- Typical natural gas is flammable in 4 to 14 percent natural gas in air mixture
- 3- In a confined space, a 4 to 14 percent mixture can be

Combustible gas indicator (CGI)

- There are two main applications for outside surveys are:
 - 1- Available Openings.
 - 2- bar holing.
- A bar hole is a small diameter hole made in the ground in the vicinity of gas piping to extract a sample of the ground atmosphere for leak analysis.
- The CGI instruments are also useful in building surveys and in areas within a building, such as heater closets, and other confined areas.
- A CGI should always be used first when entering a building to determine if a hazardous atmosphere is present.

- The cost of a CGI is substantially lower than an FI unit.

The Flame Ionization (FI)

- The Flame Ionization (FI) detector uses a hydrogen fuel to power a small flame in a detector cell.
- A pump or venturi system is used to pass continuous air samples through the detector cell.
- This is detected electronically and displayed on a meter readout.
- FI units are equipped with meters that indicate gas concentrations from 1 **Part Per Million (PPM)** to 10,000 PPM.
- They are also equipped with audible alarms to alert the operator when there is a meter deflection.
- Leak survey can be done more rapidly with an FI unit than with a CGI using the bar hole method.



Figure IV-5

The Flame Ionization (FI)
unit.

This man is checking a gas
meter for leaks with a
hand-carried FI unit.

PD (Personal Detector) Short Locator.

- The Model PD Detector acclaimed to be the fastest method known to accurately locate points of electrical contact and insulating joints on coated pipelines.
- Unaffected by parallel lines, depths or cover, the survey can often be, in part, conducted from a moving vehicle over the pipe.
- The PD Detector can be used to locate discontinuities in the coating of buried pipelines.



Receiver



Oscillator

PD Locator

PD (Personal Detector) Short Locator.

- The depth of the pipe or cable can be accurately determined without the usual bending or kneeling.
- First locate center of the pipe or line "A" by crossing the pipe in a sweeping motion.
- A "null" (no signal) will mark the center of the pipe.
- Mark this location "A", moving 90° from the pipe with bubble centered in 45° angle gauge and holding the probe tip close to the ground until another "null"- "B" is detected.

- This distance from "B" to "A" less $\frac{1}{2}$ of the outside diameter of the pipe will be the depth of the buried pipe as in Figure (I).

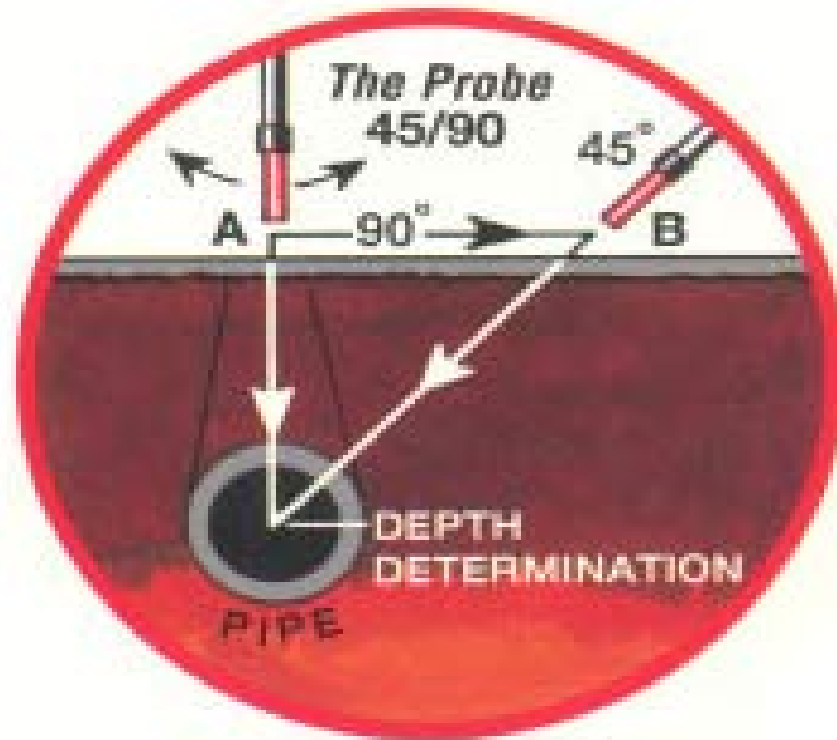

Figure (I)

Recommended Method for Surface Gas Detection Survey with FI Unit (Natural Gas System Only)

Recommended Method for Surface Gas Detection Survey with FI Unit (Natural Gas System Only)

- The ability of the gas to vent at the ground surface is critical for the success of a surface survey with an FI unit.
- FI is not to be used when the ground is frozen.
- A sampling of the atmosphere , the services should be made at ground level or at no more than 2 inches above the ground surface.
- In areas where the gas piping is under pavement, samplings , curb lines & available ground surface openings Such as:-
 - 1- manholes
 - 2- catch basins
 - 3- sewers
 - 4- Telephone duct openings.
 - 5- Fire & traffic signal boxes
 - 6- cracks in the pavement

- This figure shows leaking gas following the sewer line into the home, after leaking at the service tee. Natural gas can migrate in this manner.

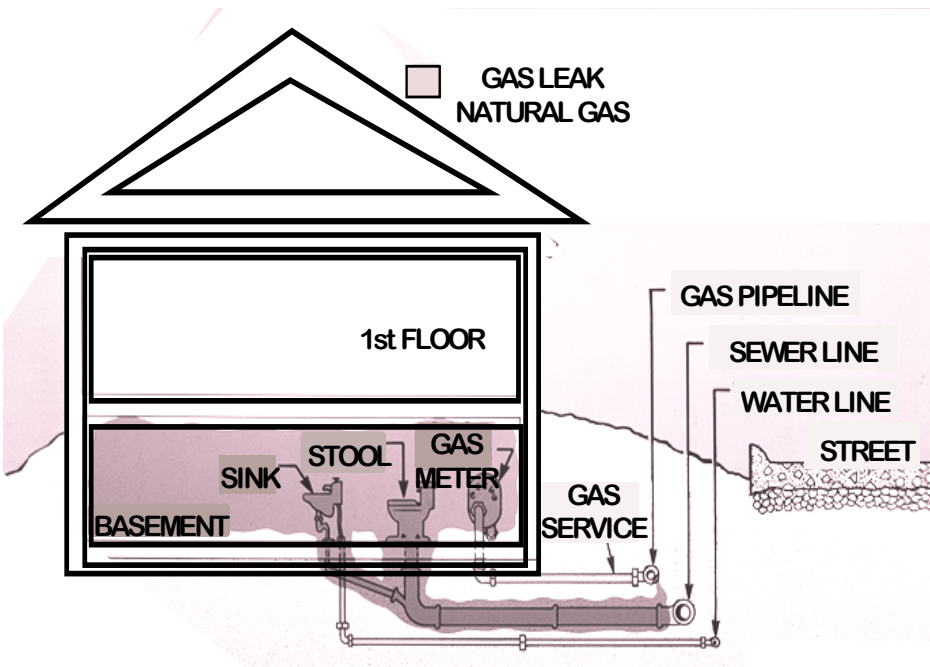

Figure IV-7

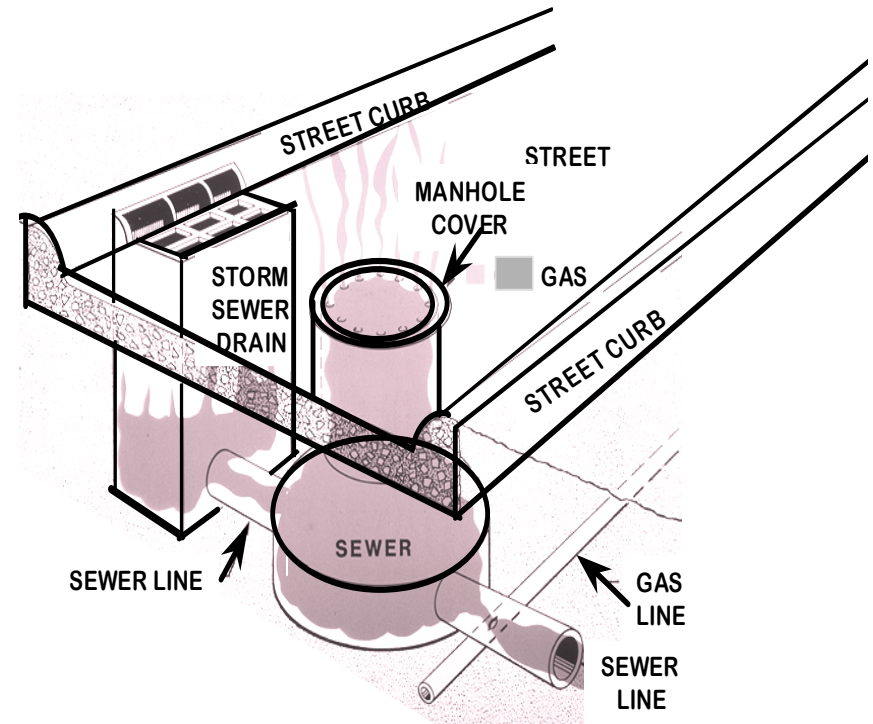

Figure IV-8

Odorants

Types of Odorants

- Most odorants used in the United States are:
 - a) Mercaptans.
 - b) Mercaptan sulfide blends.
- The only other odorant in wide use is cyclic sulfide (thiophane), which is mainly used in gas systems containing natural odorants.
- The human sense of smell is very discerning and can detect mercaptans at a concentration of only 1 **Part Per Billion (PPB)**.
- The sulfur content of the odorants in the gas stream can be measured by gas analysis, if there is sufficient odorant.
- The main types of detectors are:-
 - 1- Odor concentration meters.
 - 2- Titrators.
 - 3- Gas chromatographs.

Odorization Equipment

- The figures shows equipment which odorizes the gas.

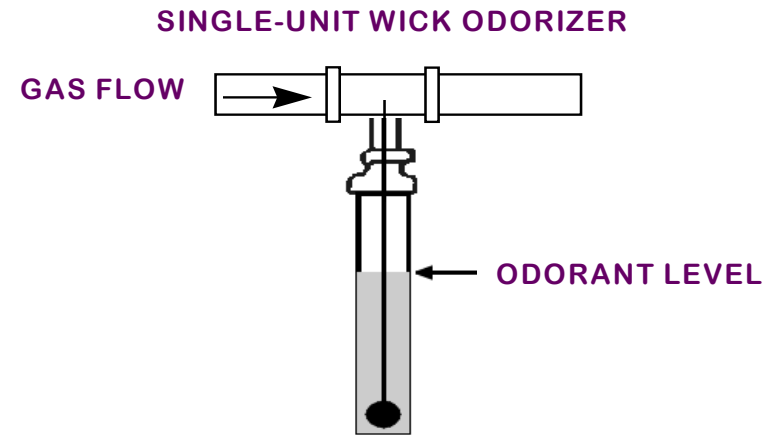
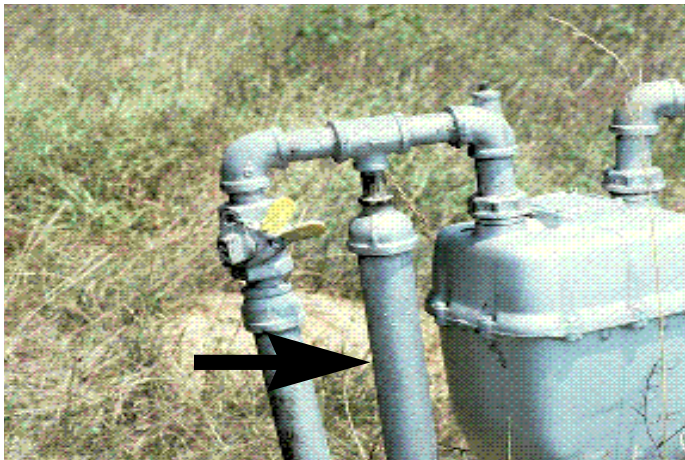

Figure IV-12

A picture of an odor testing instrument.

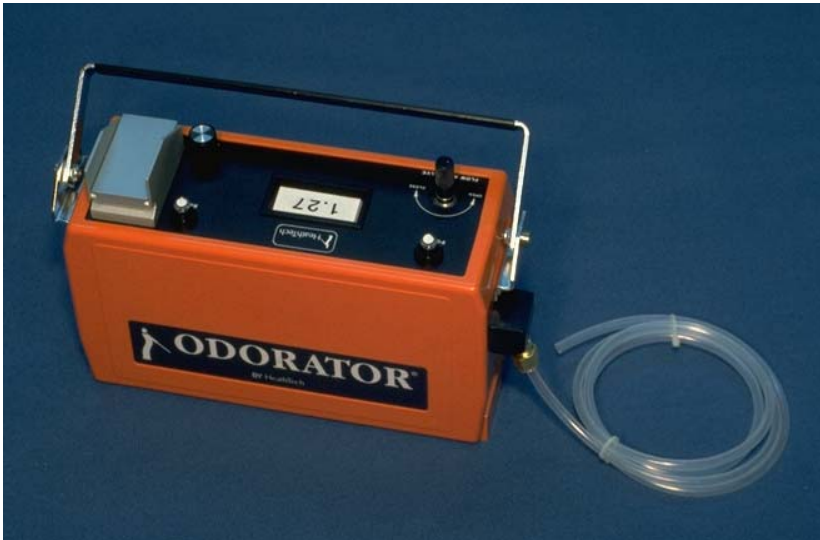
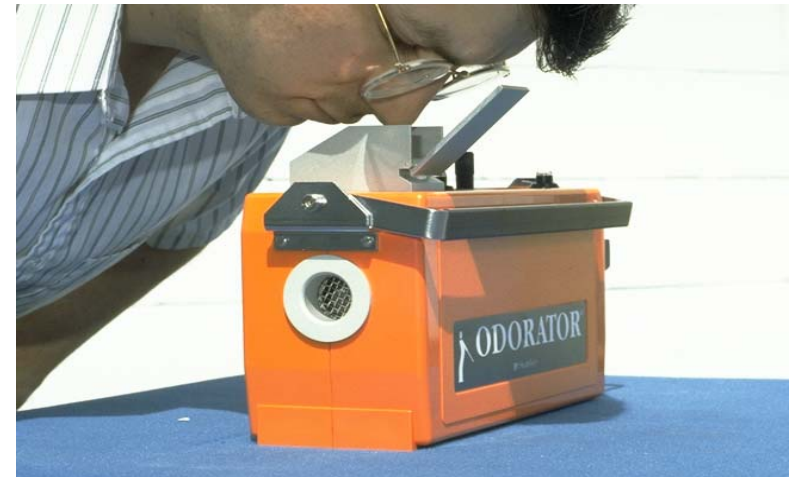

Figure IV-13

This man is conducting a sniff test using an odor testing instrument.



Follow-up Inspection

Follow-up Inspection

- The adequacy of leak repairs should be checked before backfilling.
- The perimeter of the leak area should be checked with a CGI.
- a follow-up inspection should be made as soon as practical after allowing the soil atmosphere to vent and stabilize.
- OPS suggests follow-up inspection within 24 to 48 hours.

A method to remember when investigating gas leaks and determining it as follows:

- Where is the gas ?
(Use a detector to confirm gas is present)
- How much is there ?
(Take readings on the CGI)
- Extent of the spread?
(Determine the migration pattern)
- Relation to other structures ?
(Is gas detected in or near buildings or in manholes?)
- Evaluate/evacuate?
(Classify the leak and take appropriate action)

Leak Classification and Action Criteria

Leak Classification and Action Criteria

- **There is three grades of classification and action criteria:**

1- Grade-1

2- Grade-2

3- Grade-3

Grade-1

- A leak that represents an existing or probable hazard to persons or property, and requires immediate repair or continuous action until the conditions are no longer hazardous.
- Requires prompt action to protect life and property.

Grade-2

- A leak that is recognized as being non-hazardous at the time of detection, but justifies scheduled repair based on probable future hazard.
- Leaks should be repaired or cleared within one calendar year, but no later than 15 months from the date the leak was reported.

Grade-3

- A leak that is non-hazardous at the time of detection and can be reasonably expected to remain non-hazardous.
- These leaks should be re-evaluated during the next scheduled survey, or within 15 months of the date reported.

Conclusion:

- 1- There is Methods of Detecting a Leak in Pipes.
- 2- Leak Detection Instruments Must be Apply Immediately.
- 3- Can Detect any leak in pipes by Leak Detection Equipment.
- 4- Surface Gas Detection Can Be Detected By Survey with FI Unit.
- 5- Can easily Detect gas leaking by Odorants.
- 6- Follow-up Inspection is Very important.
- 7- There is Classification for Leak .

WHAT IS SCADA ?

ما هو نظام الاسكادا

SCADA

Supervisory Control And Data Acquisition

نظام المراقبة والتحكم وجمع البيانات

ما هو نظام الاسكادا؟

الاسكادا هي نظام تكنولوجي يمكن استخدامها من جمع بيانات من مواقع بعيدة ومراقبة تشغيل هذه المواقع وإرسال أوامر التشغيل للتحكم في هذه المواقع مثل غلق أو فتح الصمامات أو تغيير ال Set Point أو غلق المحطة بالكامل في حالة الطوارئ ، وهذا دون الحاجة إلي وجود أشخاص للتشغيل في هذه المواقع في ظروف التشغيل العادية .

What is SCADA?

SCADA is the technology that enables a user to collect data from distant facilities , supervise the operation and send control instructions to those facilities as closing or opening valves ,changing set points or shutdown in case of emergency , so there is no need to assign operators to those facilities in normal operating conditions.

IMPORTANCE OF SCADA:-

أهمية نظام الاسكادا

-إمكانية المراقبة والتحكم فى شبكة الغاز بكل تفاصيلها والتي يمكن أن تمتد إلى آلاف الكيلومترات.

- The ability of monitoring and control the gas network with its details which can be extended to thousands of kilometers.

-تحليل بيانات التشغيل وتخزينها لمدد طويلة.

- Operational data analyses and storage for long periods (historical).

-إعداد تقارير التشغيل اليومية والدورية.

- Operational data daily and periodically reporting.

-تسجيل الأحداث وأوامر التشغيل وكذلك الإنذارات.

- Logging of selected events and operator actions and warning alarms.

- The ease of upgrading or reconfiguring the system as adding or omitting

gas pipelines, gas stations or even the signals transmitted from stations

to dispatch center by persons who have this permission through an

engineering terminal without operational interruption.

- Remote diagnostics and upgrading for RTU's.

SCADA

Supervision

Monitoring of operation parameters such as press., temp., flow,.....

Data Acquisition

Remotely using telecomm. Networks to connect control sites to control centers.

Control

Issuing control commands to fulfill operation demands

Supervisory Control And Data Acquisition System For The Egyptian National Gas Grid

Is integrated system used to remotely monitor and control different gas activities in Egypt and is known as **SCADA** for abbreviation

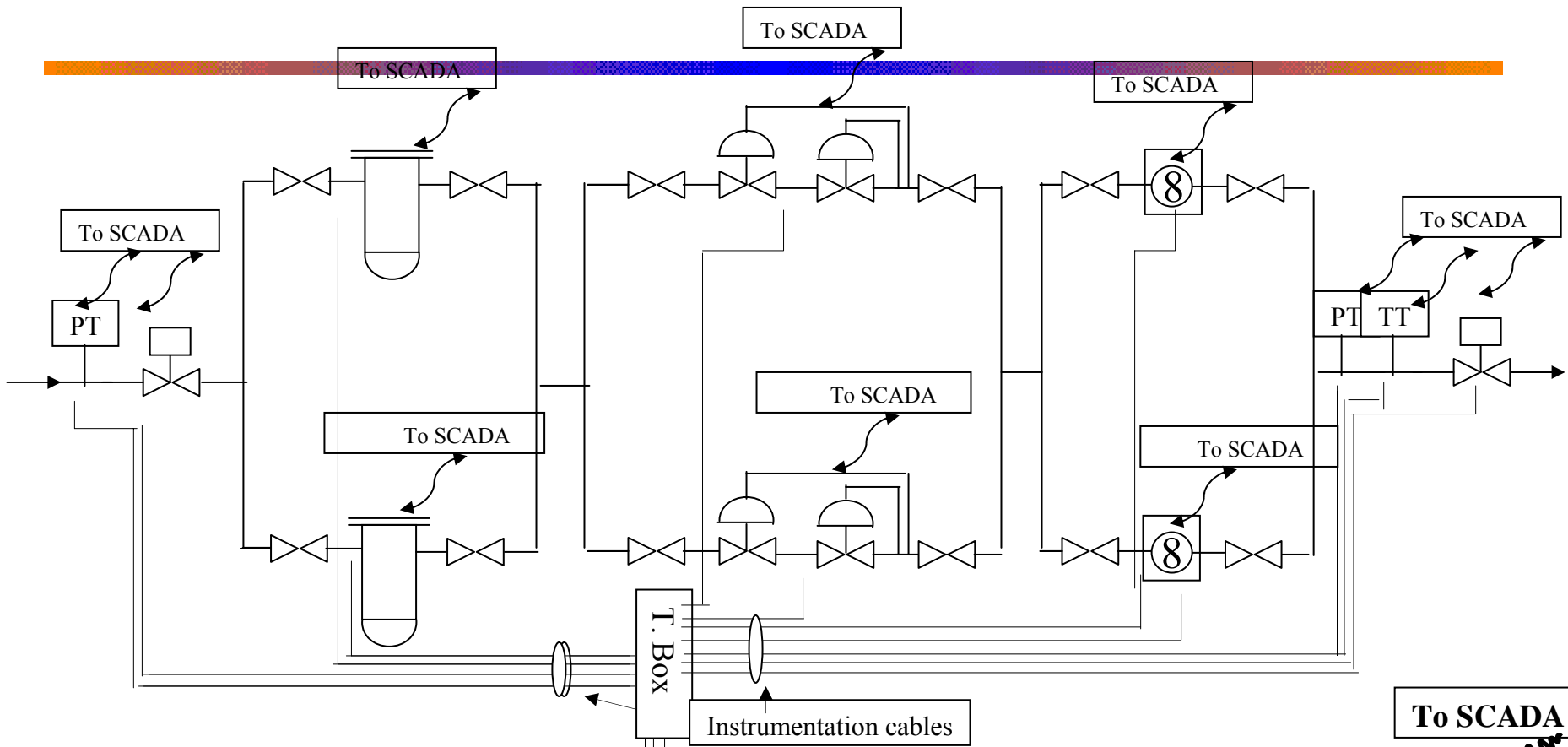

To SCADA

R & M Station

Instrumentation cables

T. Box

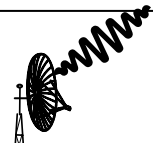
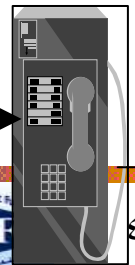
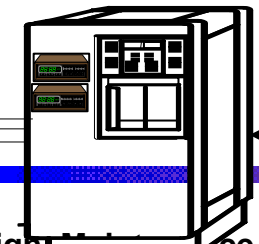

Control panel

Operation Philosophy

- Each local control center collects the information of control sites in its geographical area and perform local monitoring.
- ~~This information is transmitted to the main control center for central monitoring.~~
- Control is done centrally from the main control center by sending the control information to local centers.
- In case of failure of a local control center the main control center takes over its role until it comes back and then updates it with lost data during the failure period.
- The main control center is designed in redundant configuration to ensure reliable and secure control over the grid, only a force major could cause the main control centre to fail.
- ~~In case of main control center failure the emergency control center takes over until it comes back and then updates it with~~

Applying this operation philosophy guarantees continuous and safe control over the gas grid

المركز القومي للتحكم في الغاز - National Center for Gas Control

مركز التحكم المحلي والطوارئ - منطقة الدلتا - Local Control and Emergency Center - Delta Region

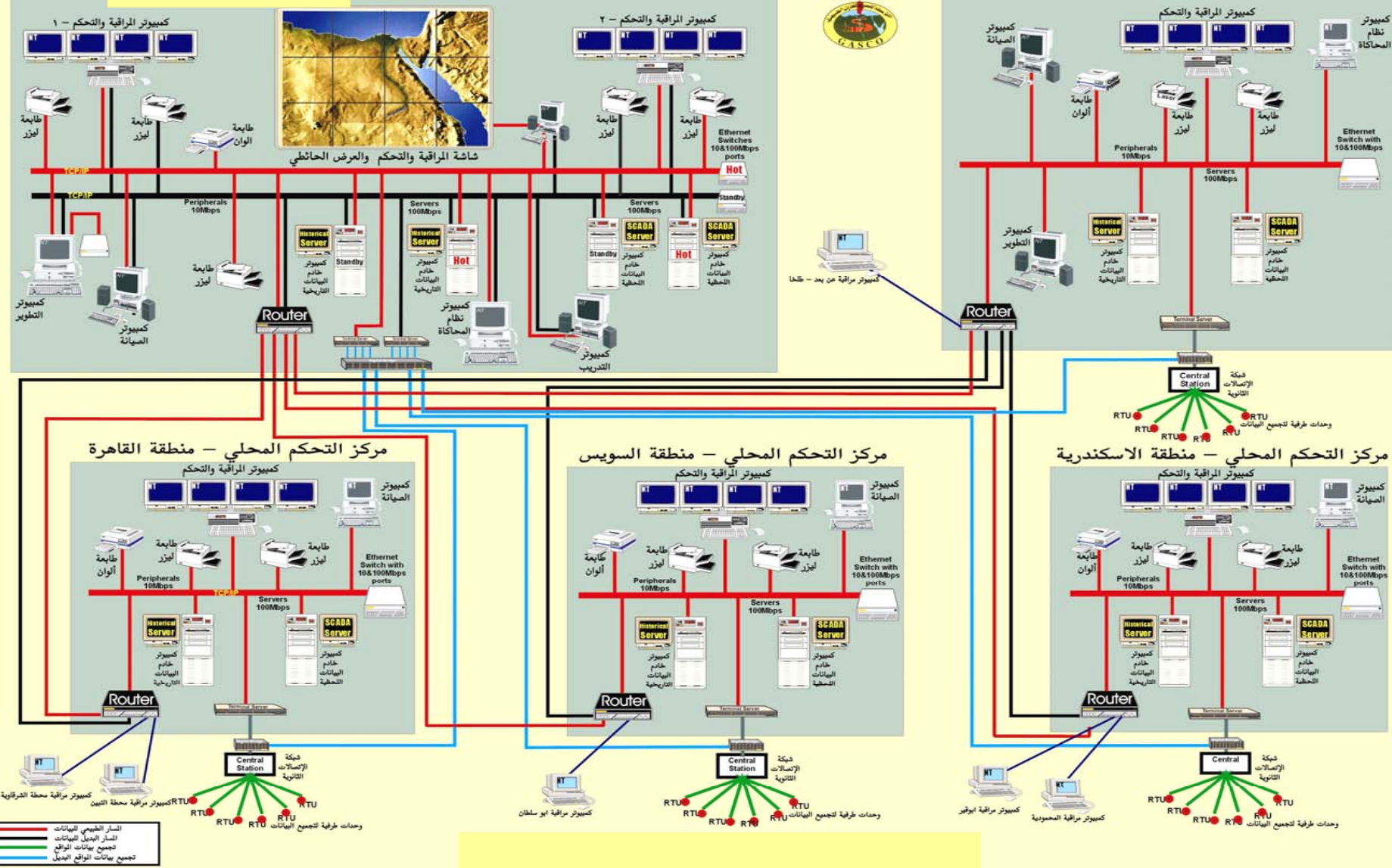

كمبيوتر مراقبة عن بعد - سلكيا

- السار الطبيعي للبيانات
- السار للبيانات للتحكم
- تجميع بيانات الواقع
- تجميع بيانات الواقع المبدئي

System Objective

The main objective of the system is to protect the huge investments in the national gas grid via:

- Providing remote monitoring and control over the whole pipelines network.
- Proposing operation scenarios for different operating circumstances and in emergency situations.
- Leak and break detection in pipelines network.
- Facilitate decision support systems.
- Integration with other application such as gas accounting and billing system.
- Remote administration and maintenance of different system components.
- Telecomm systems are utilized to provide voice and data communications between all system's sites independently of third-party service providers

Gas Grid Information

The System Serves (about) :

Gas Grid Length: 3000 Km

Grid Capacity: 100 SMCM/Day

Bulk Consumers: 250

Gas Fields: 15

Components of National Gas Grid SCADA System

The system consists of:

- Remote Terminal Units RTUs
- Control Centers
- Telecomm networks
- Software packages

First Remote Terminal Units



The RTU Is a special computer designed to process data between control sites and local control centers



Second Control Centers

4 Control centers cover geographically the whole gas grid

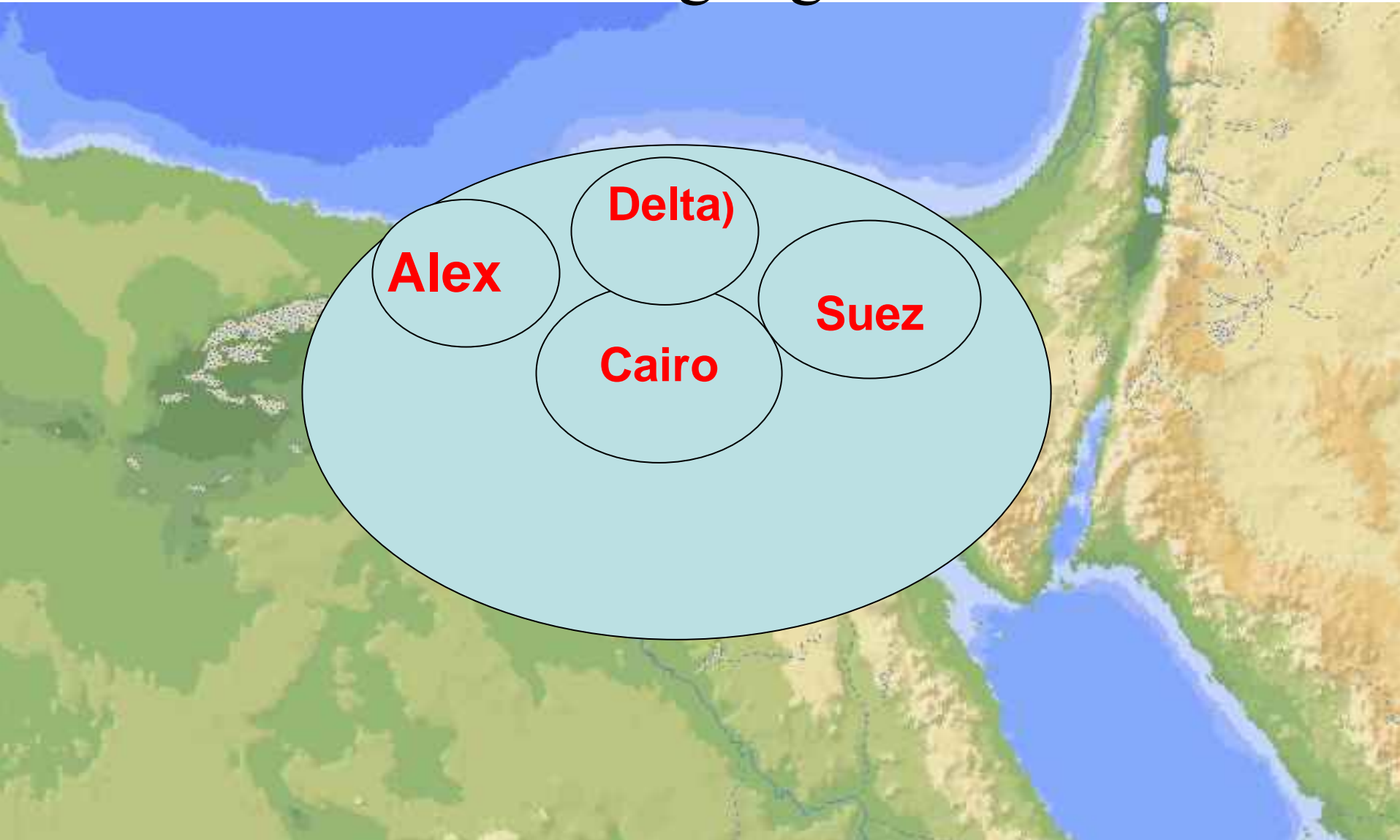

The main control center is located in **Cairo** and is responsible for monitoring and control of the national gas grid. The center is designed in redundant configuration for reliable operation. It takes the role of local control centers in case of failure, and it consists of:

The main control center

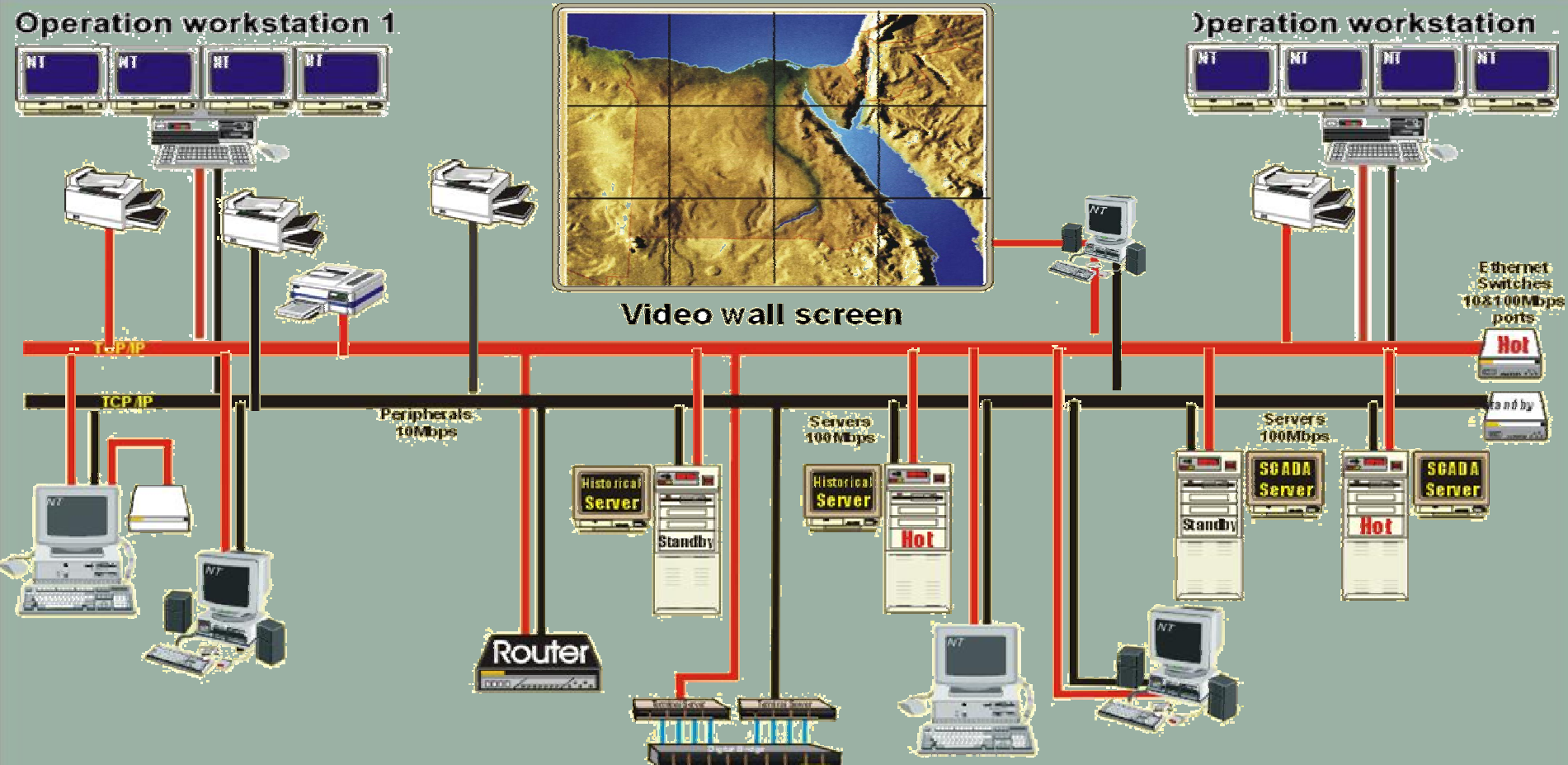

Local control centers are located in **Delta**, **Alexandria**, **Suez**, and **Cairo**. Each control center gathers the operation data for its local sites and perform control actions, then it transmit this data to the main control center.

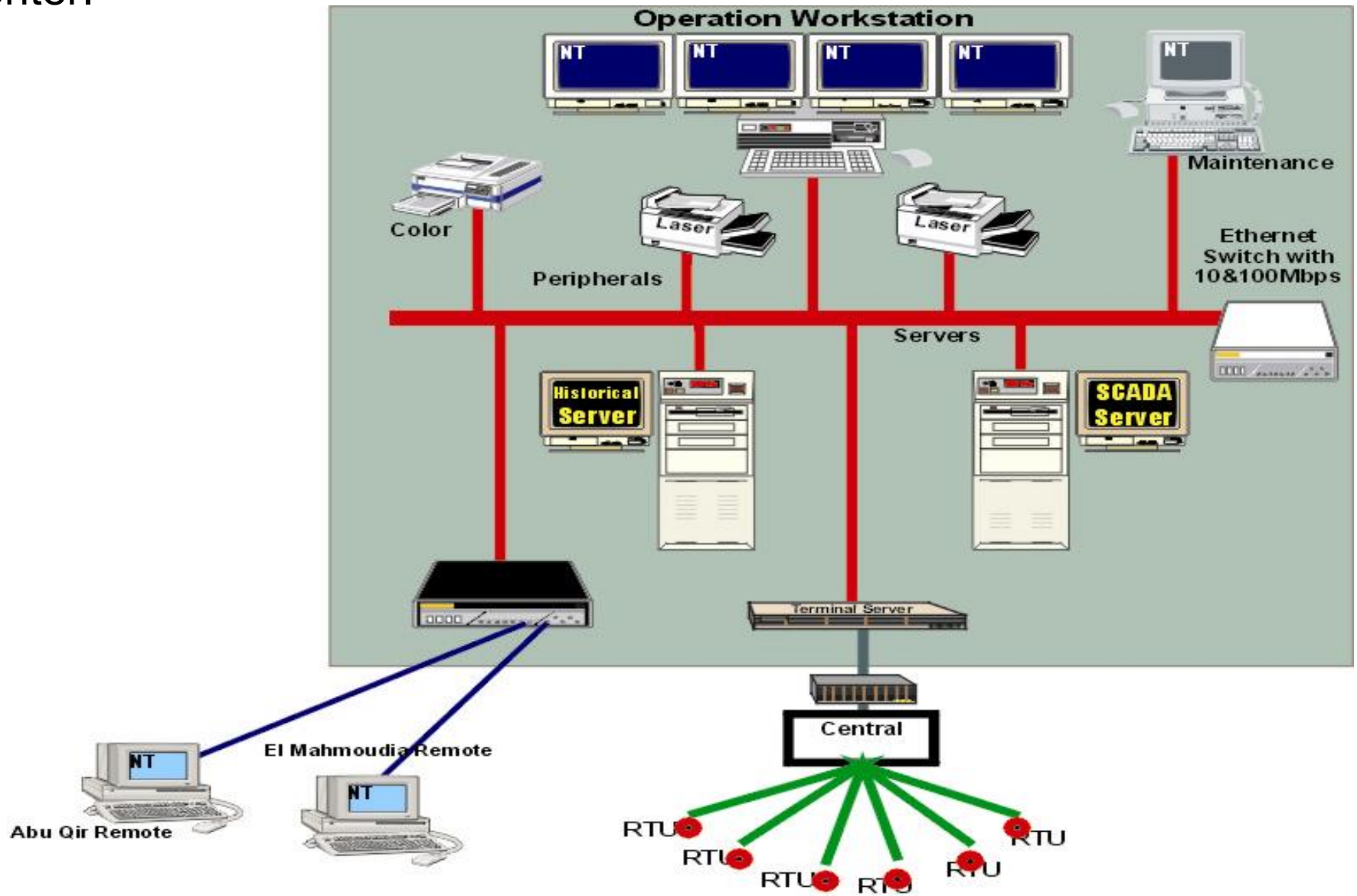

Emergency control center is designed to take over the role of the main control center in case of emergency or failure.

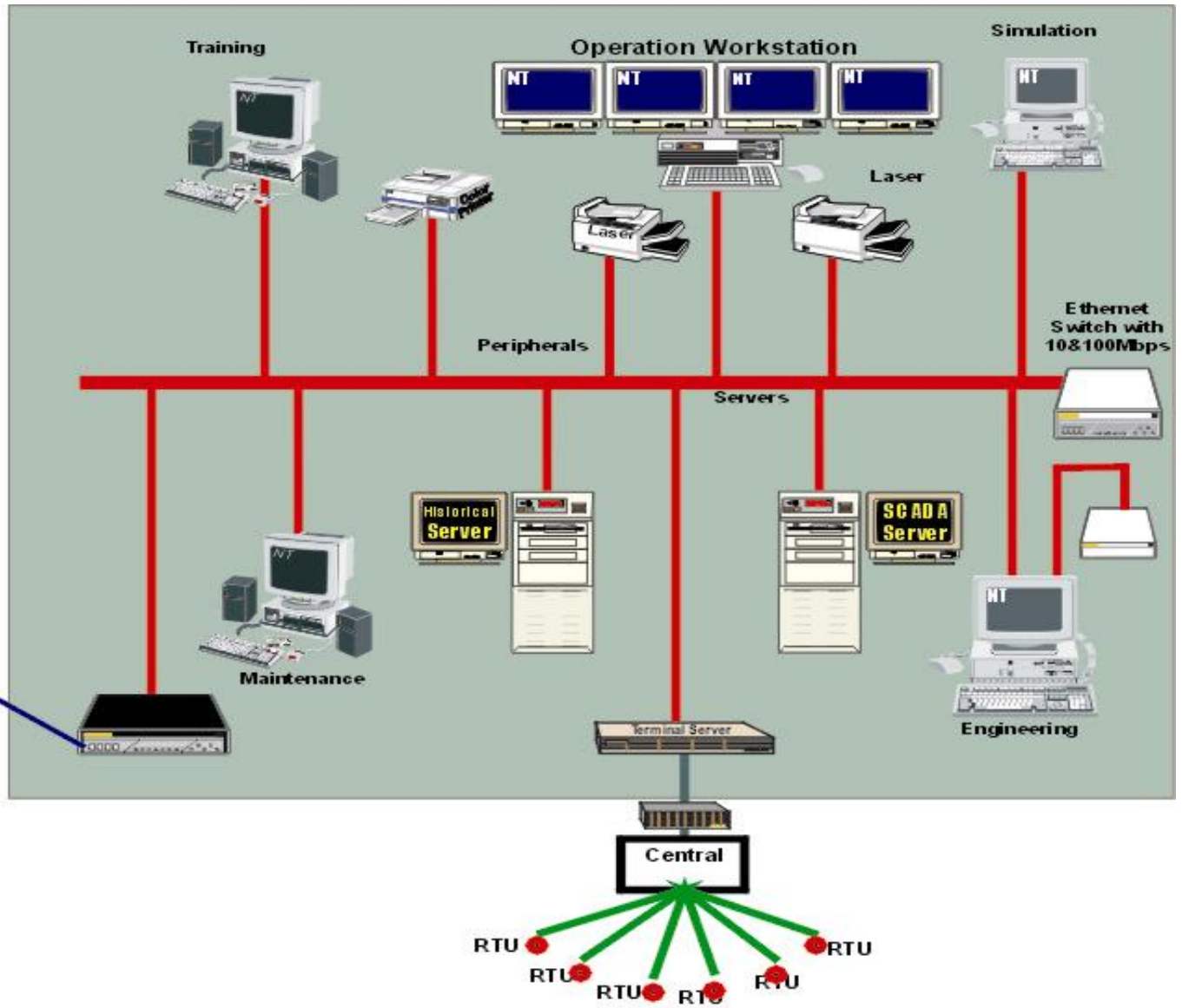
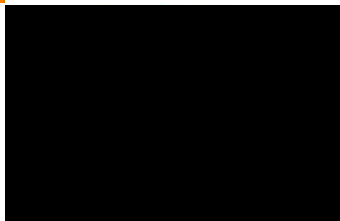

Third Telecommunication Networks

An integrated high speed digital telecomm. Network covers the whole gas grid, while providing voice and data services between grid sites.



Primary digital microwave network working in the 7 Giga band, indicated in red color and is used for data transmission between control centers.

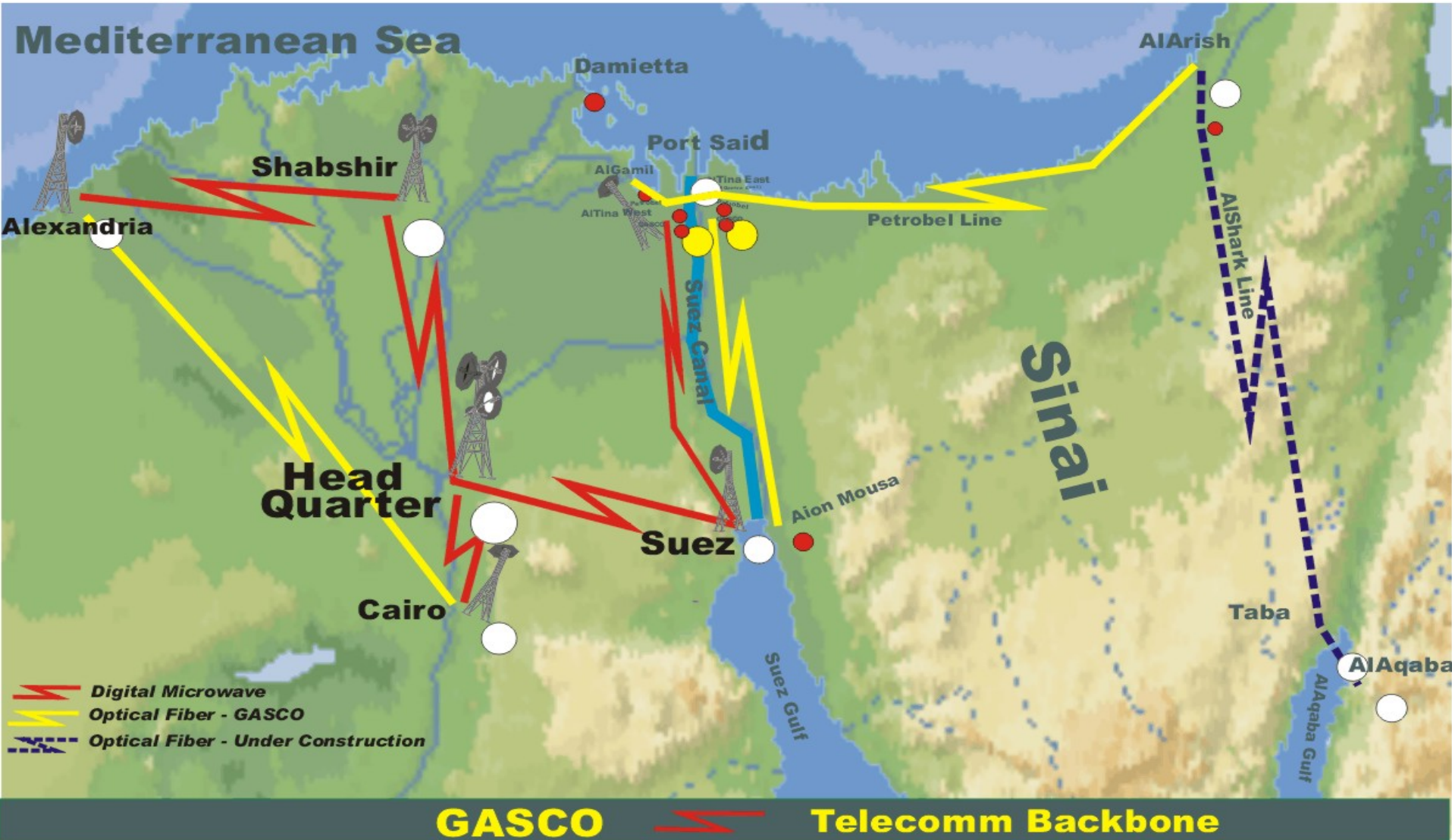

Optical fiber network and is usually installed with recent pipelines. It is indicated in *yellow* colors. Fiber optics network is used to transmit data between control centers and also transmit operation information of the pipeline.

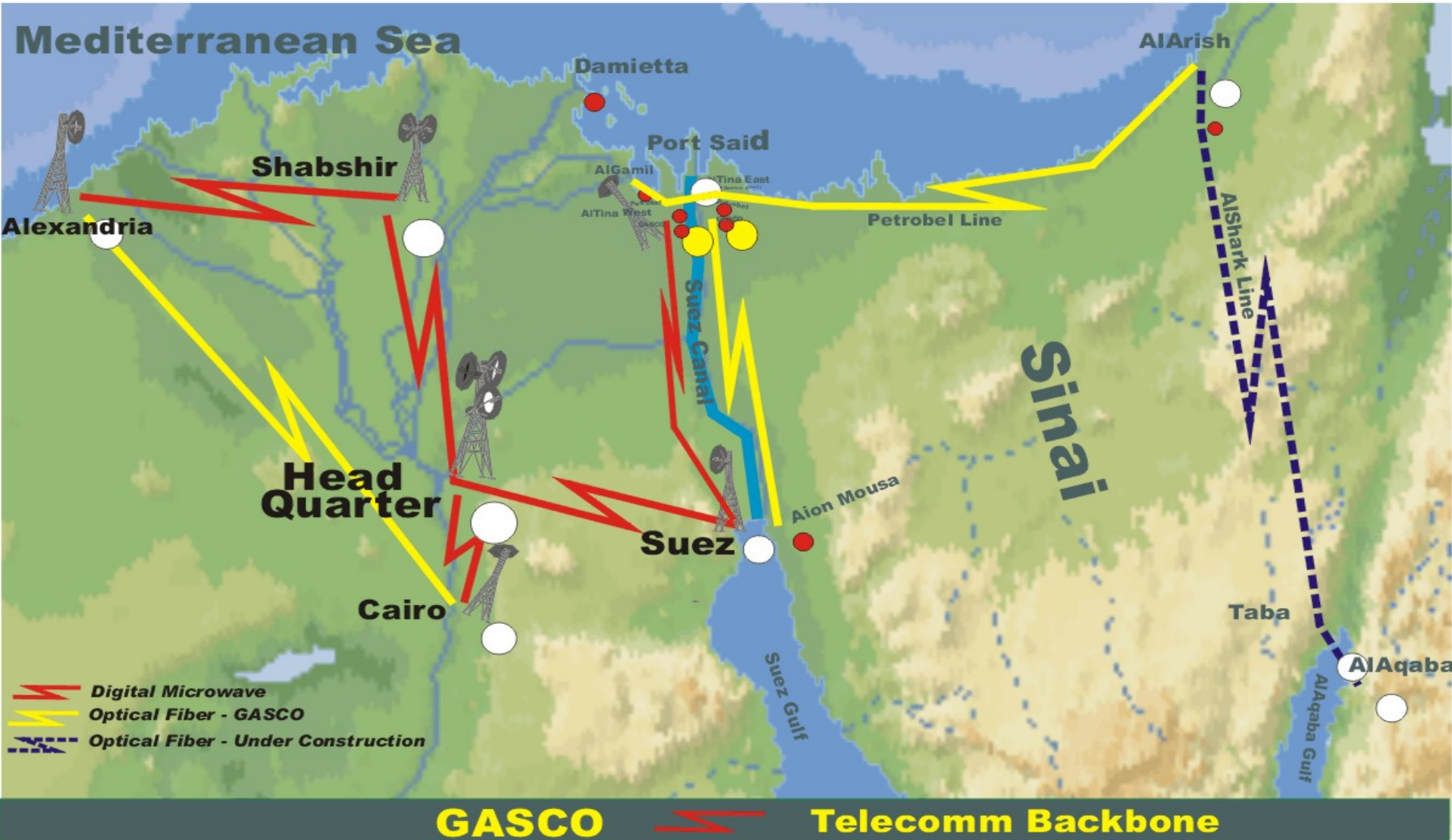

Secondary digital microwave network consisting of 4 local networks covering the whole gas grid and is working in the 2.4 Giga band. This network is used to connect production, consumers, and dispatching sites to the local control center.

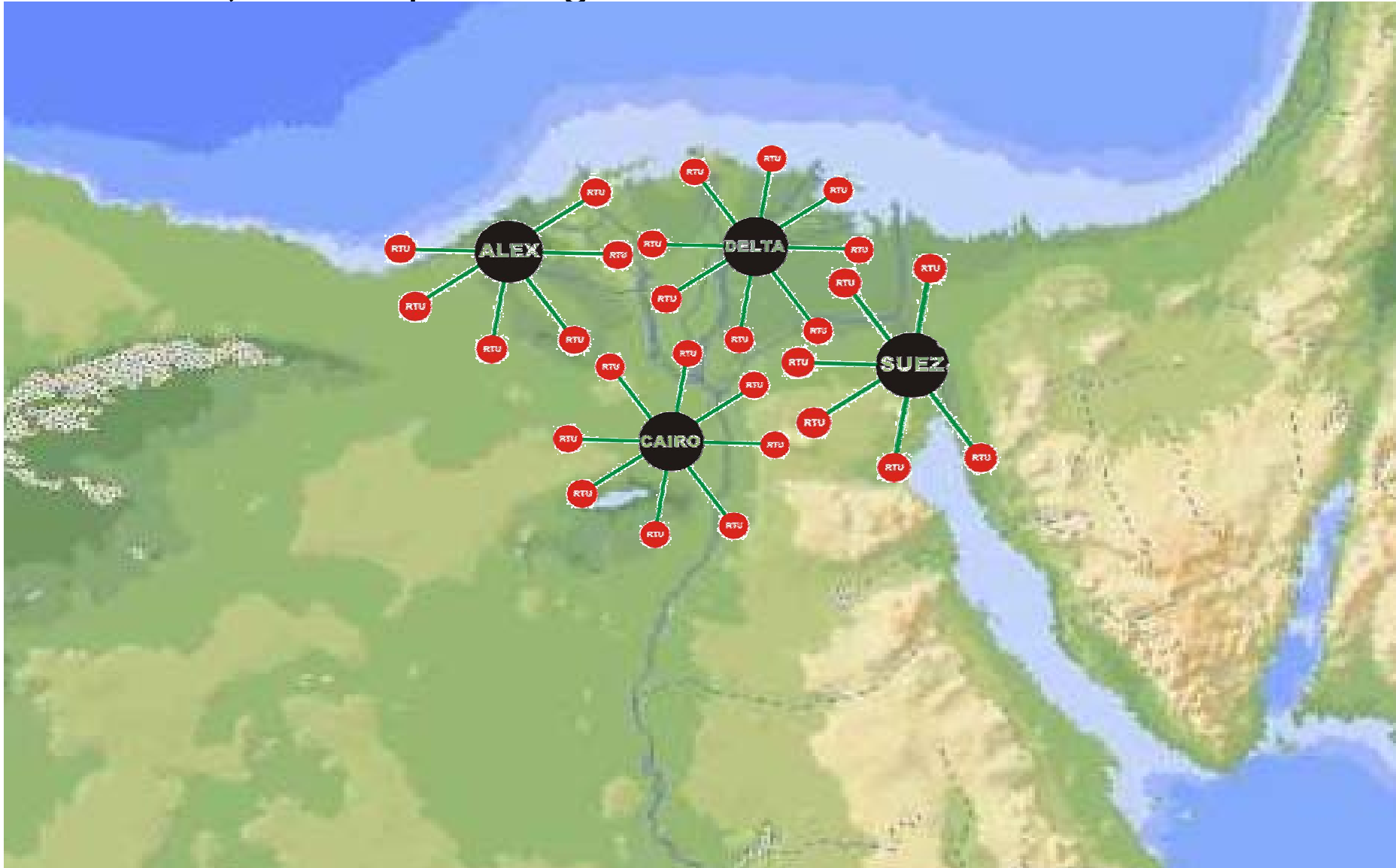

Fourth Application Software Packages

Application Software Packages

- SCADA software package.
- Network management software packages.
- Gas grid simulation software is doing grid analysis and accordingly proposing operation scenarios in different circumstances. It detects leak and line break, also predict their places. It performs other functions that ensure GASCO high security measures.

References:-

- **Leak Detection, 49 CFR, Part 192.**
- **From Net:**

-

www.caltechindia.com