

# Oil and Gas Pipeline Design, Maintenance and Repair

---

Dr. Abdel-Alim Hashem

Professor of Petroleum Engineering

Mining, Petroleum & Metallurgical Eng. Dept.

Faculty of Engineering – Cairo University

[aelsayed@mail.eng.cu.edu.eg](mailto:aelsayed@mail.eng.cu.edu.eg)

[ahshem2000@yahoo.com](mailto:ahshem2000@yahoo.com)

## Part 6: Planning and Construction of Pipeline

# CONTENTS

- Procedures Involved in Planning and Construction of New Pipelines
- Measures to Allow Pipeline Expansion
- Bending of Pipes
- Connecting Pipes
- Flanges (Joints)
- Other Mechanical Joints
- Welding, Boring and Tunneling to Install Pipe - Trenchless Technologies
- Horizontal Earth Boring
- Horizontal Auger Boring
- Microtunneling

- Horizontal Directional Drilling (HOD)
- Pipe Jacking,
- Tunneling, Comments on Trenchless Construction,
- Pipeline Construction in Marsh and Swamp
- Offshore Construction
- Cold-Region Construction
- Freezing
- Temperature Variation
- Environmental Concerns
- Other Considerations

# PROCEDURES OF PLANNING AND CONSTRUCTION

- Planning and construction of any new pipeline system depends on several factors
  - Material (fluid or solid) to be transported by the pipeline (whether it is natural gas, oil, water, sewage, slurry or capsules),
  - Length of the pipeline
  - Environment (whether the pipeline is in an urban or countryside setting, on land or offshore, warm climate or cold climate)
- More similarities than dissimilarities in constructing different types of pipelines
- Once a person understands how a given type of pipeline is built, it is not difficult to figure out how another type should be built.

# PROCEDURES OF PLANNING AND CONSTRUCTION

Procedures used for long-distance steel gas or oil pipelines

- Step 1: Preliminary planning
- Step 2: Route selection
- Step 3: Acquisition of right-of-way
- Step 4: Soil borings, testing of soil and other data collection
- Step 5: Pipeline design
- Step 6: Seek legal permits
- Step 7: Start construction
  1. Right-of-way preparation
  2. Stringing

# PROCEDURES OF PLANNING AND CONSTRUCTION

---

3. Ditching and trenching
  4. Boring
  5. Tunneling
  6. River crossing
  7. Welding, coating, and wrapping
  8. Pipe laying
  9. Backfill and restoration of land
- For a long pipeline, the foregoing procedure is applied to a portion of the pipeline (say. a few miles) at a time
  - After the portion is completed, the same procedure is applied to the next portion.

# MEASURES TO ALLOW PIPELINE EXPANSION

- Places affected by thermal expansion, earthquake, soil settlement, etc., allow pipelines to expand (elongate) freely in order to prevent development of large stresses in the pipe.
- This is especially true for PVC pipes and concrete pipes, which expand several times more than steel pipes due to temperature change.
- Even for steel pipes that are aboveground, allowance must be made for expansion and shrinkage caused by seasonal weather change
- Build a zigzagged instead of straight pipeline to provide allowance for thermal expansion or shrinkage
- Zigzags move freely either outward (during expansion) or inward (during shrinkage).

# MEASURES TO ALLOW PIPELINE EXPANSION

- This is common for both aboveground and underground pipelines.
- For pipelines above ground, sometimes an inverted U or loop is used instead.
- Special joints are available for expansion
  - Bell-and-spigot joints
  - Slip joints, swivel joints
  - Certain mechanical joints.
- For small diameter pipe, using a joint made of flexible pipe (hose) will allow expansion.

# BENDING OF PIPES

- Pipes bent to follow sudden grade changes, or change in the horizontal direction of the pipeline
- done conveniently in the field (outdoors) by using a cold bending method
- Hot bending, produces better results, more cumbersome and costly
- Done in shops rather than in the field
- When a pipe is bent, cross section of the pipe deformed from a circular to an oval shape, the thickness of the pipe wall on the outer side of the bend is also reduced due to stretching
- This is called thinning



# SHOP HOT BENDING

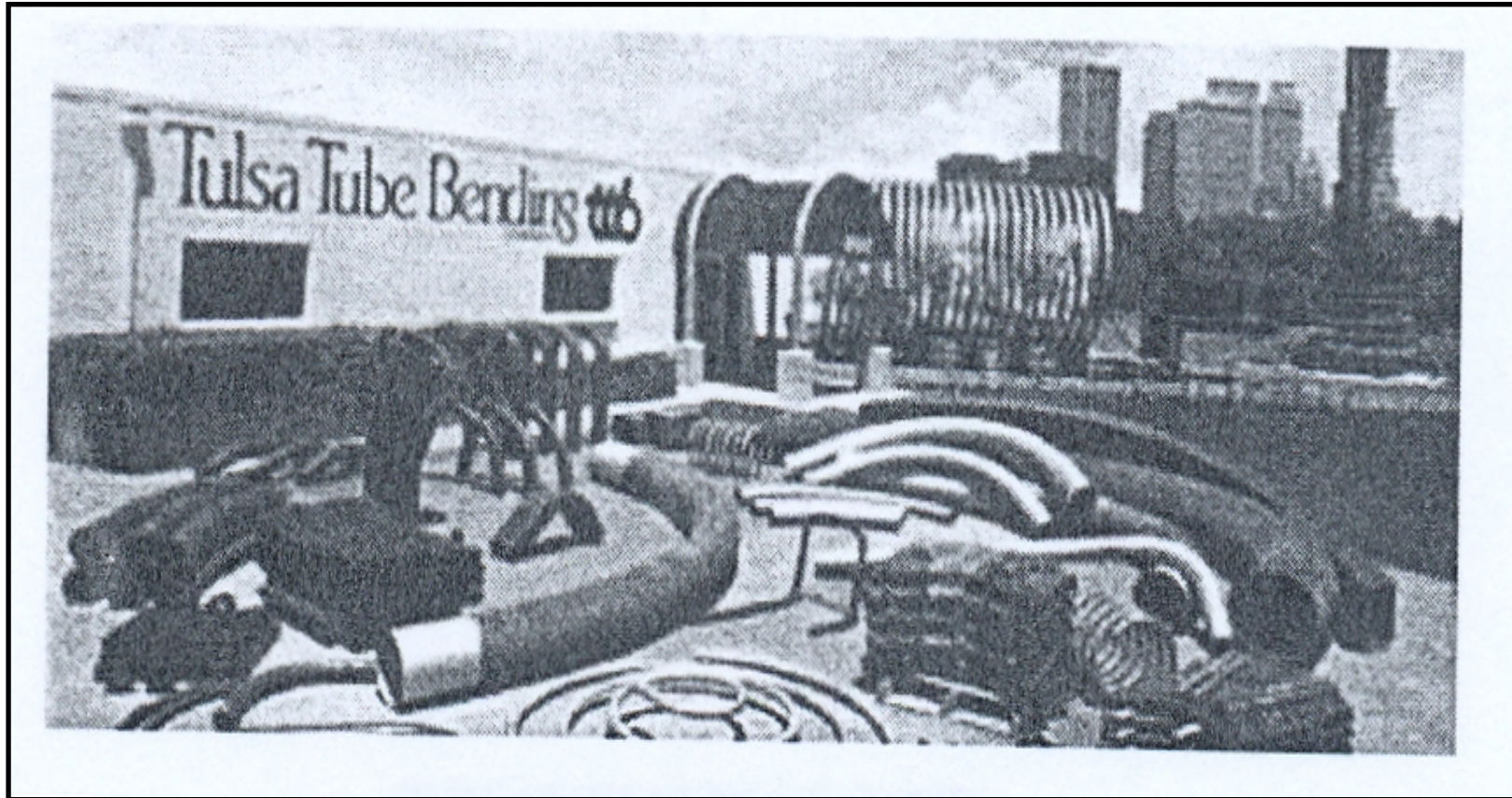

Courtesy Tulsa Tube Bending Company

# BENDING METHODS FOR STEEL PIPE

- **Compression bending** - pressing a pipe with a moving roller against and around a stationary die
- **Draw bending** - similar to compression bending except that a mandrel is inserted through one end of the pipe.
- **Ram bending** - A ram (punch) with a hemispherical head is pressed against one side of a pipe supported at two neighboring points by two pivoted blocks, rollers, or clamps
- **Internal roll bender (Rotoform)** - A French machine that uses a rolling head rotating inside a pipe.
- **Induction bending** - pipe passes through a special section at which a strong magnetic field is generated to heat the pipe locally.

# Compression Bending

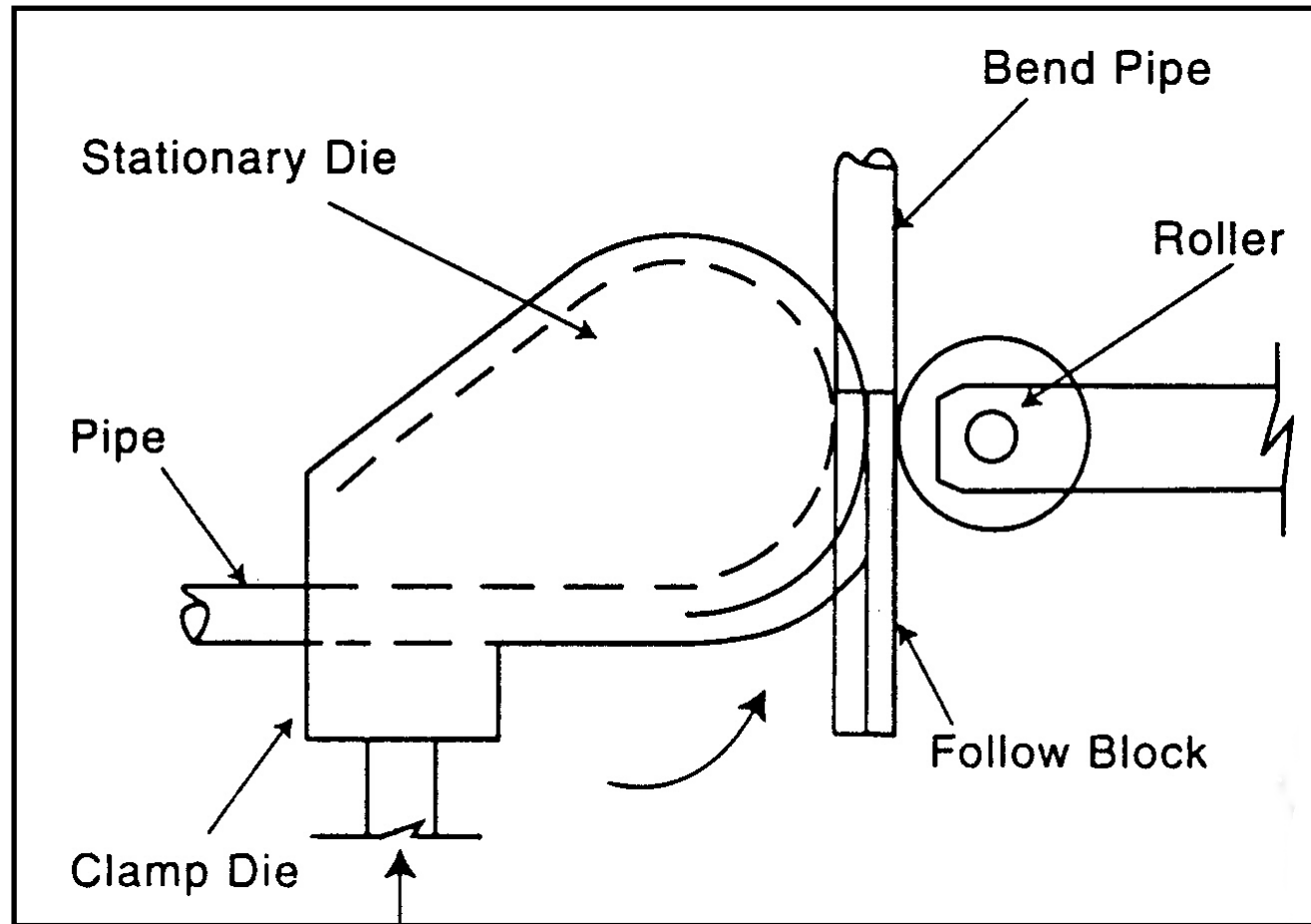

# Draw Bending

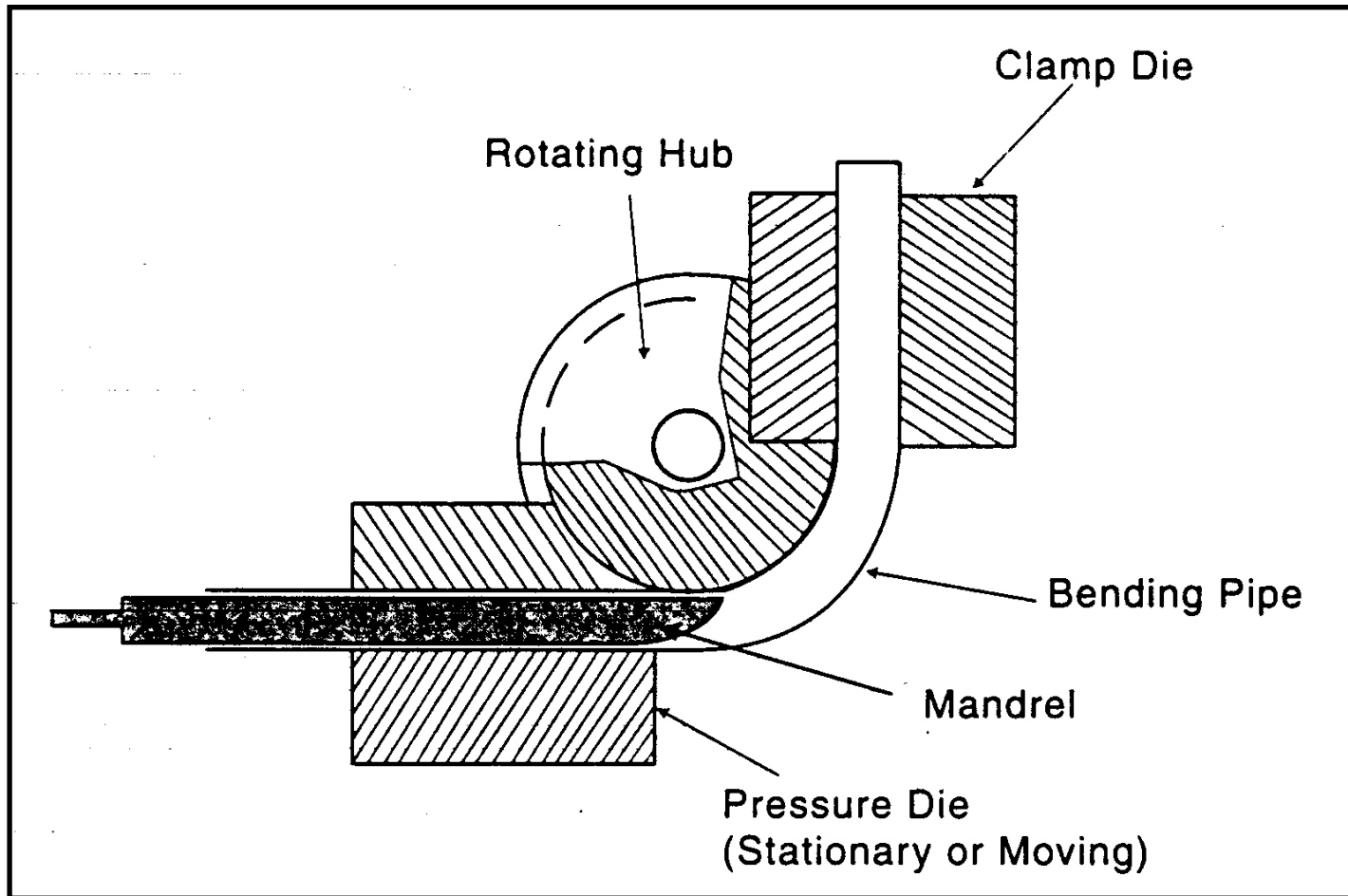

# Ram Bending

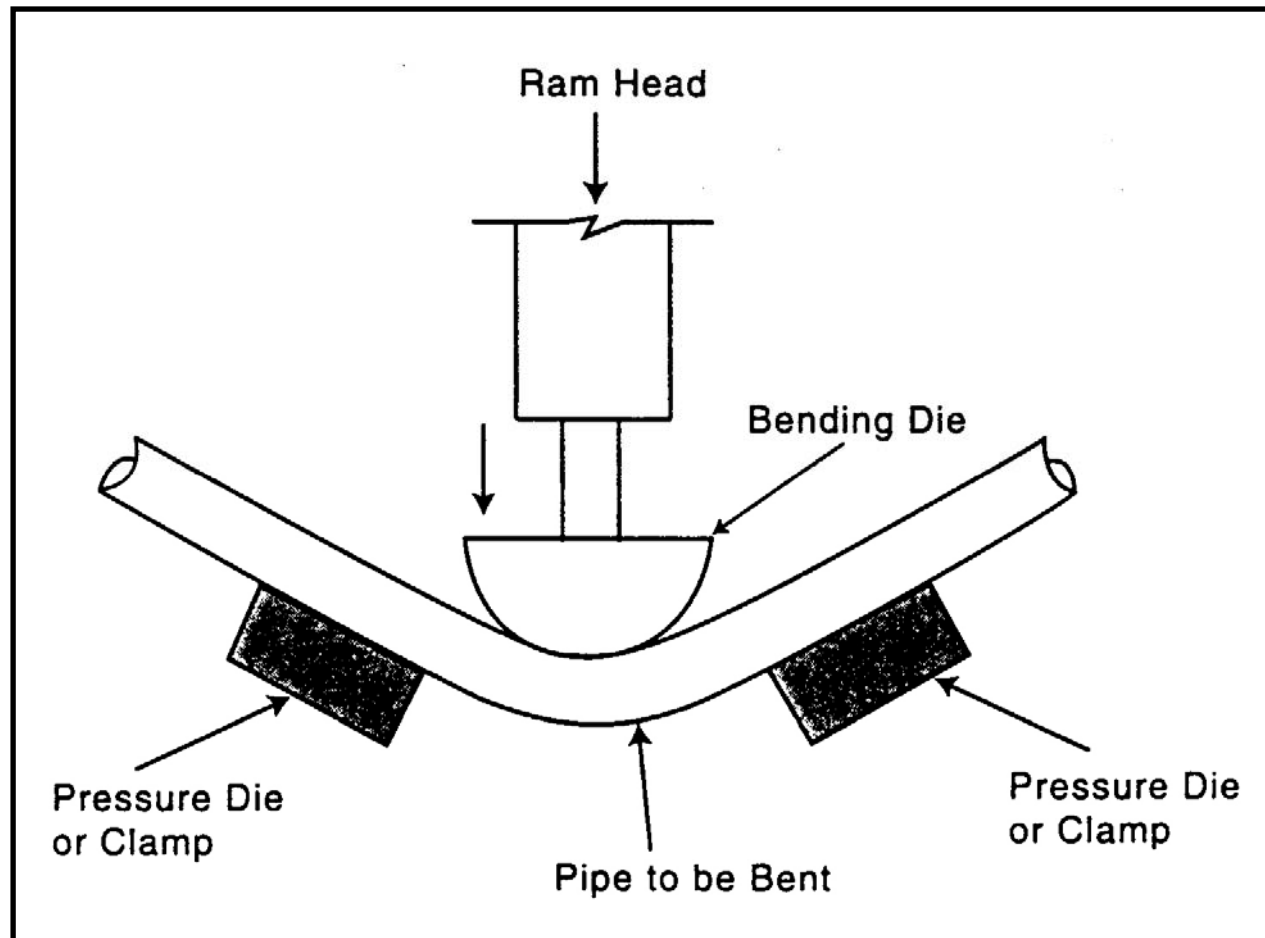

# Induction-bending Machine

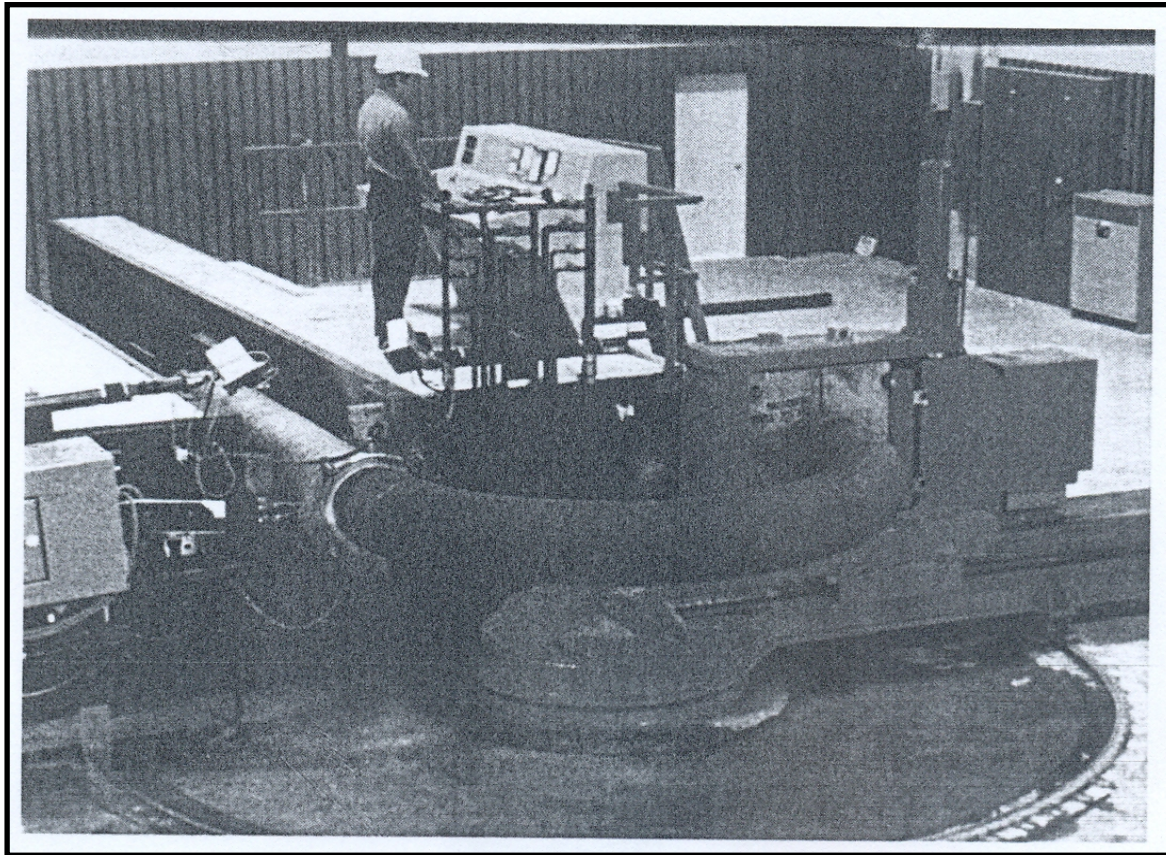

Courtesy of Tulsa Tube Bending Company

# CONNECTING PIPES

- Pipes available in sections or segments\* of 20-ft length.
- For steel pipes, the maximum section length is usually 40 ft.
- Segments transported to the construction site
- Before being laid in ditches, sections joined (connected) together to form a long pipeline
- Joining can be done in several ways including
  - Flanged joints
  - Other mechanical joints
  - Welding

# Long Distance Pipe





# Ditching



# Welding A 24-in Steel Pipe Using an Electric Arc and an Internal Lineup Damp

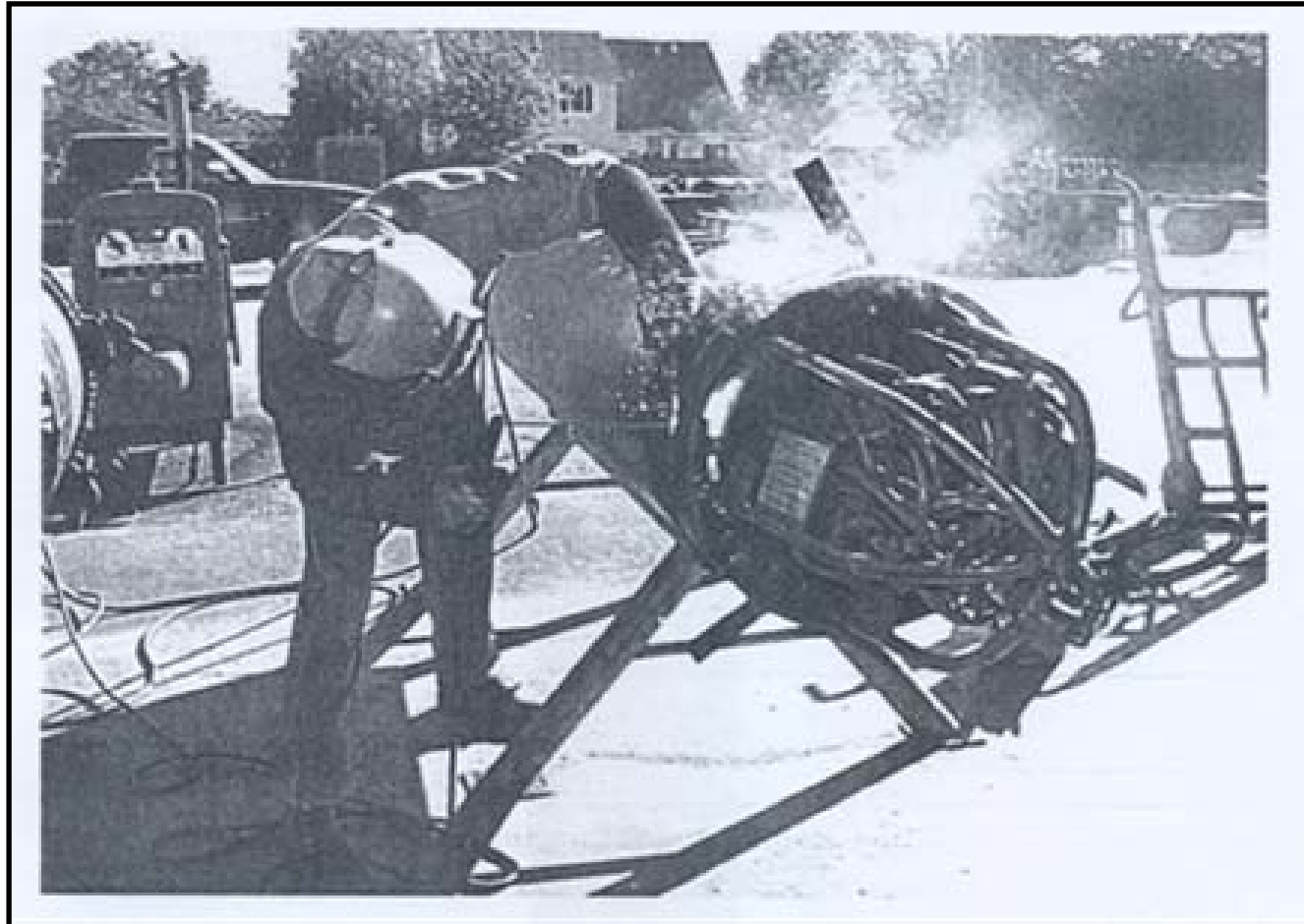

# Pipeline Welding Defects

- Under cutting الحز الدائري
  - Due to technique mistakes
- Accumulation of discontinuity تراكم عدم اتصال المعدن
  - Long time interval between the welding path
- Cracks شروخ
  - Shrinkage of metal due metallurgical errors
- Porosity or gas pockets المسامية
  - Resulting of the welding metals metallurgical properties

# Pipeline Welding Defects

- Slag inclusion خبث حبيس
  - Existence of non-metallic material between the welding and the pipe metal
- Burn through المجري النافذ (انتفاخ للحام علي السطح)
  - Error in welding material selection
- Incomplete fusion صهر غير كامل
  - Fast welding movement
  - Dirty pipe surface
  - Existence of gas between welding and pipe
- Inadequate penetration تغلغل غير كافي
  - Incomplete bevel ends
  - Fast welding movement

# Welding Inspection and Testing

- There are two inspection methods:
  - Non-destructive test (NDT)
    - Visual inspection (not accurate)
    - Radiographic (x-ray or gamma ray)
  - Destructive test (DT)
    - This could be done by taking a sample of the welding part and test it in the lab
    - Location of the sample should be according to API standard
    - The tests could be tension, bending and impact

# BORING AND TUNNELING - TRENCHLESS TECHNOLOGIES

- To minimize construction costs, the open-cut (ditching and trenching) method to lay pipe
- Generally used in rural and remote locations
- Exception crossing rivers, lakes, roads, and other obstacles
- Crossing such obstacles, other alternatives as
  - Rerouting the pipeline,
  - Using or building a bridge (for river crossing)
  - Underground construction – boring and tunneling

# Horizontal Earth Boring (HEB)

- Uses a machine that bores a horizontal or nearly horizontal hole (small tunnel) underground for laying pipes beneath obstacles such as a roadway.
- The boring and subsequent installation of pipes is done by a machine without workers being present in the borehole.
- Three types of HEB
  - Horizontal auger boring
  - Micro-tunneling
  - Horizontal directional drilling

# Horizontal Auger Boring

- Components of horizontal auger boring (HAB) include
  - a cutting head, a set of cutters mounted on the front face of the boring machine, cut earth by the rotation of the cutters
  - an auger: front end connected to the cutting head and tail end connected to the prime mover that drives the system, to convey the spoil (i.e., the earth or rock that has been cut loose) to outside the borehole:
  - a nonrotating casing around the rotating auger, which is the pipe to be installed
  - a prime mover that provides the torque to rotate the auger and the cutters and provides the thrust to advance the pipe (casing) along with the cutting head and the auger;



# Horizontal Auger Boring

- a system to inject bentonite slurry around the pipe to reduce friction between the pipe and the surrounding earth in order to facilitate the advancement of the pipe during the action of boring;
- a system to receive, store, process, and recycle the bentonite slurry
- control and monitoring equipment. The entire boring system is controlled from outside the borehole, and no human needs to be present inside the borehole or pipe
- The system can lay pipes of diameters as small as a few inches. and as large as several feet.

# A Horizontal Earth-boring Machine



Courtesy Herenknecht Company and Ruhr-University of Bochum, Germany

# Microtunneling

- Microtunneling is the high-tech version of the horizontal earth-boring system
- Invented and first used in Japan in the 1970s.
- Uses a laser-guided and remote-controlled pipe jacking system
- Permits accurate monitoring and control of the horizontal direction and the grade of the pipe
- Because no human entry into the pipe or tunnel is needed, the technology is applicable to small as well as large pipes
- Used most for installing pipes of less than 1m diameter
- The system is rather versatile.

# Microtunneling

- Applicable to all types of soil, and a large variety of depths (up to about 50 m below ground), either above or below groundwater table.
- Best suited for installing sewer pipes, which normally require accurate grade and alignment.
- One of two methods is used to remove the cut materials (spoil) from the pipe.
  - The first method uses an auger.
  - The second method involves using slurry to mix with the spoil for hydraulic removal by pipes.
- The slurry facilitates cutting, and creates enough pressure in front of the machine to prevent or reduce infiltration of groundwater into the borehole.

# Horizontal Directional Drilling (HDD)

- HDD is a new technology borrowed from the oil and gas industries, which have been using it for decades for deep-well drilling of oil and natural gas.
- In the mid 1970s, the technology was adapted to making horizontal or nearly horizontal drillings across rivers and other obstacles, for installing pipes and utility cables - including power lines and lines for fiber optics.
- Commonly referred to as horizontal drilling, in order to differentiate it from the vertical or nearly vertical drillings for oil and natural gas.
- Also referred to as directional drilling, for the drill head is guided by an operator or a computer to maintain the predetermined drill path and to alter the path as needed.
- Prior to drilling and installing the pipe, a trailer-mounted drill rig is brought to one side of the obstacle to be crossed, such as a river

# Horizontal Directional Drilling (HDD) for Laying Pipelines Under Rivers

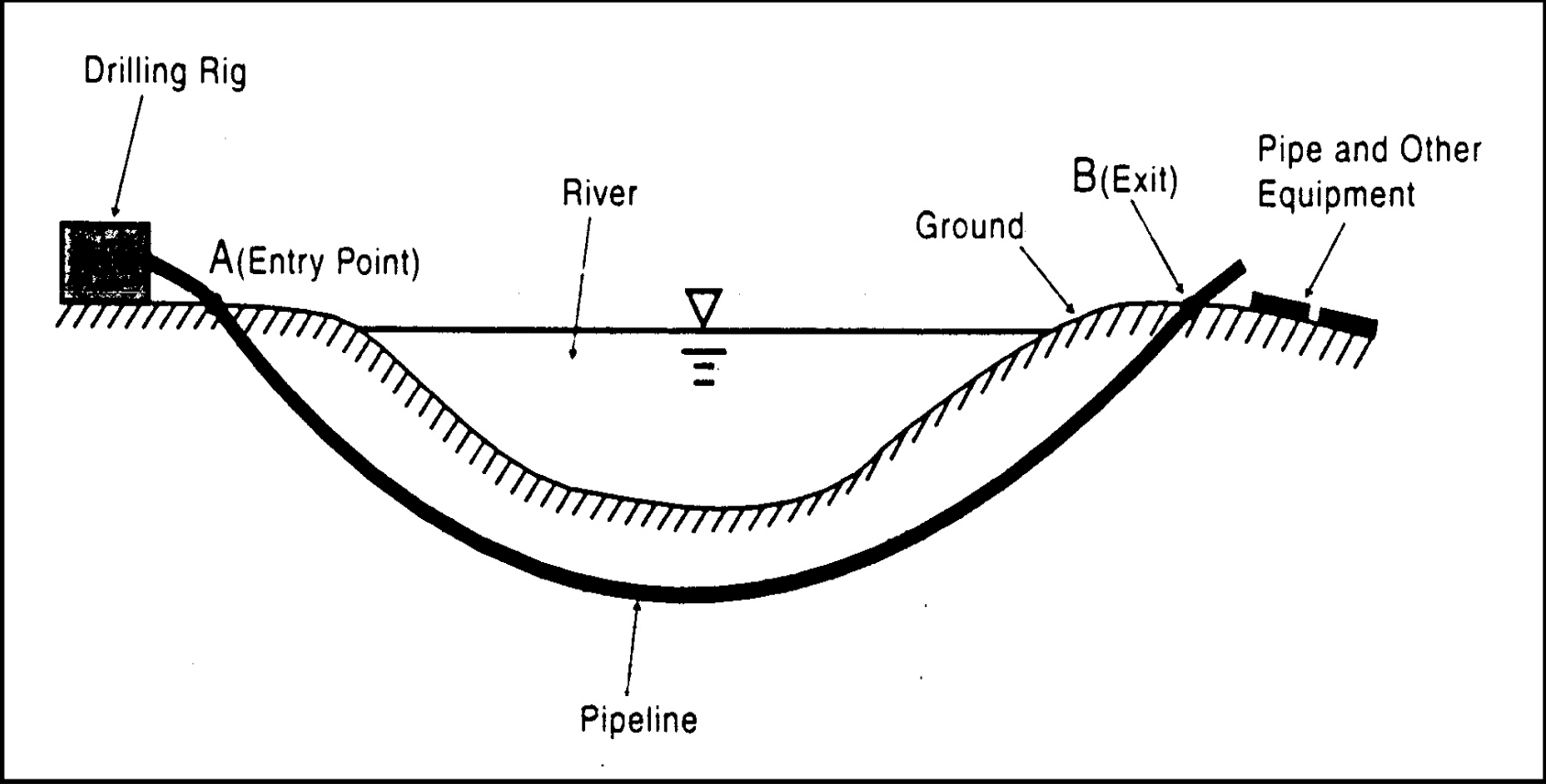

# Horizontal Directional Drilling (HDD) Machine in Operation

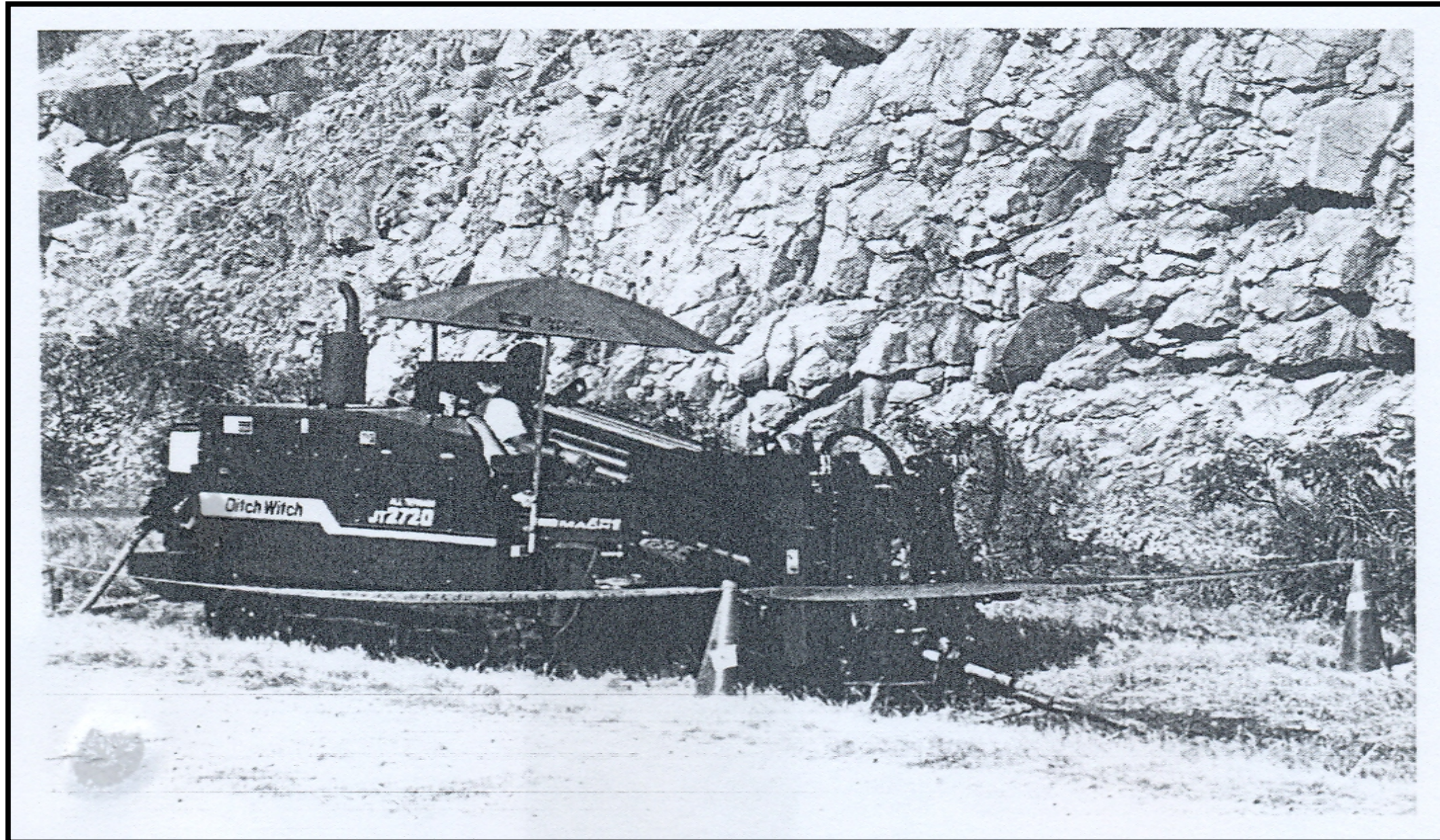

Courtesy of Ditch Witch Company

# PIPE JACKING

- Pipe jacking involves cutting the soil and simultaneously jacking (i.e. pushing by a machine) into the earth
- Pipe is sufficiently large to allow construction workers to enter the pipe for removal of the earth inside the jacked pipe, and to operate the tunnel boring machine.
- Common technology used for installing large new sewers across existing roadways without making an open cut of the road and without interfering with the traffic on the road
- To apply this method, a jacking pit or shaft is dug on one side of the road to be crossed to contain the jacking machine and sections of the pipe to be used (jacked)



# TUNNELING

- Removal of the spoil from a regular (large) tunnel and supplying the concrete and other materials needed for tunnel construction
- Done by various means such as building a temporary railroad or conveyor belt, or by using freight pipelines such as the pneumatic capsule pipeline (PCP).
- Using a freight pipeline for tunnel construction has a number of advantages over using rail or other vehicles, including
  - it has no moving part outside the pipe and hence is very safe;
  - it is powered pneumatically, and hence it has no exhaust gas and causes no air pollution in the tunnel;
  - the prime movers - the motor and the blower - are located outside the tunnel and hence do not take up the narrow space in the tunnel; and
  - the system transports large quantities of material at high speed. The only major limitation of the system is that the size of any article to be transported by PCP must be smaller than the capsule diameter or pipe diameter.

# COMMENTS ON TRENCH LESS CONSTRUCTION

The popularity of trenchless technology is growing because

- Less damage to city streets and less interruption to traffic aboveground than by open-cut construction,
- Less air pollution and less noise caused during construction than by the open-cut method,
- Deeper laying of pipes than practical for open cuts, lessens the chance of accidental damage to the pipe from other construction activities
- More economical than the open-cut method in many circumstances when damage to other structures by open cuts is taken into account, and
- More suitable for difficult ground conditions, such as unstable soil, high watertable, or when the ground is congested with other utilities.

# PCP system in Japan used for the Akima tunnel for bullet trains

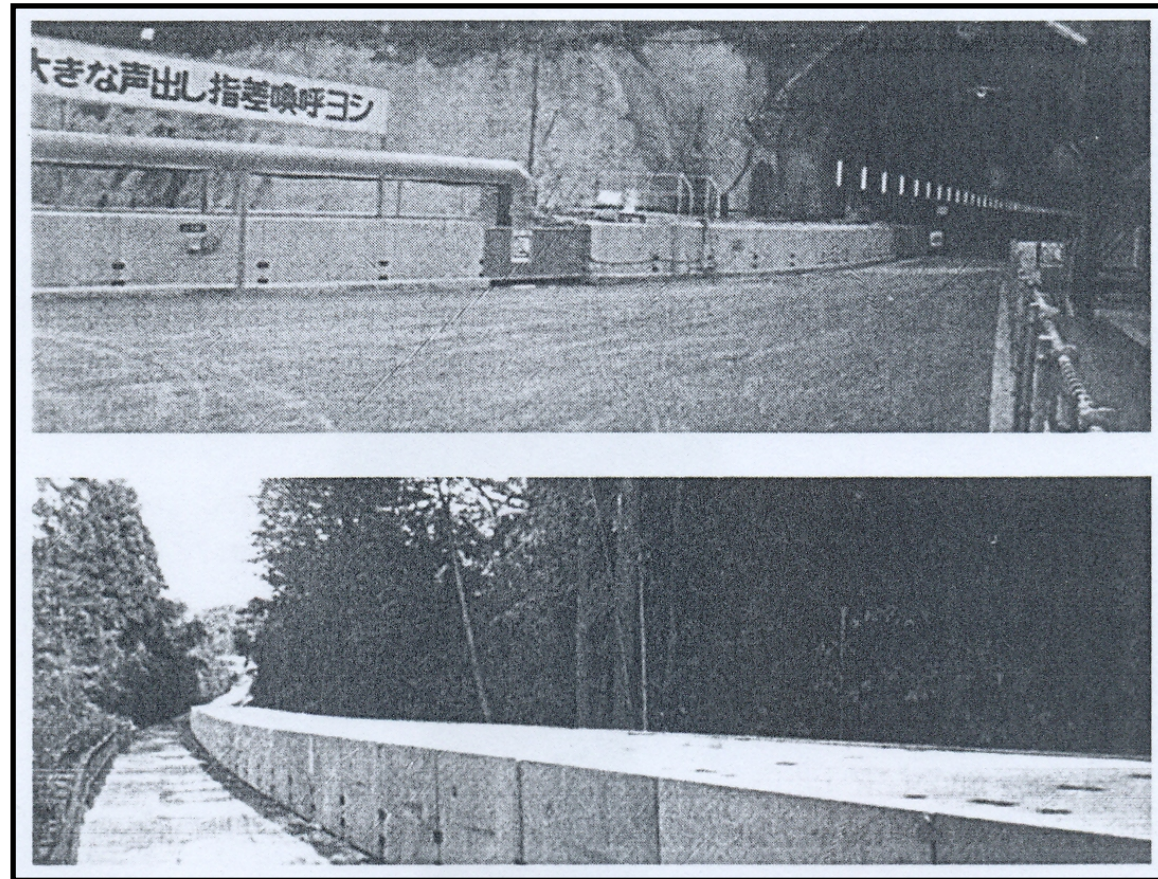

Courtesy of Sumitomo Metal Industries, Ltd

# PIPELINE CONSTRUCTION IN MARSH AND SWAMP

- The U.S. has extensive experience in dealing with pipeline construction in marsh and swamp.
- The difference between marsh and swamp is the type of vegetations encountered.
- While only small vegetation such as grass, bush or water hyacinth, are present in marsh, trees are present in swamps.
- Trees have deep roots and are difficult to remove by ordinary construction equipment.
- Construction in swamp is more difficult than in marsh, and requires a somewhat different approach.
- In both marsh and swamp, a shallow layer of water exists, and the soil is unstable.

# OFFSHORE CONSTRUCTION

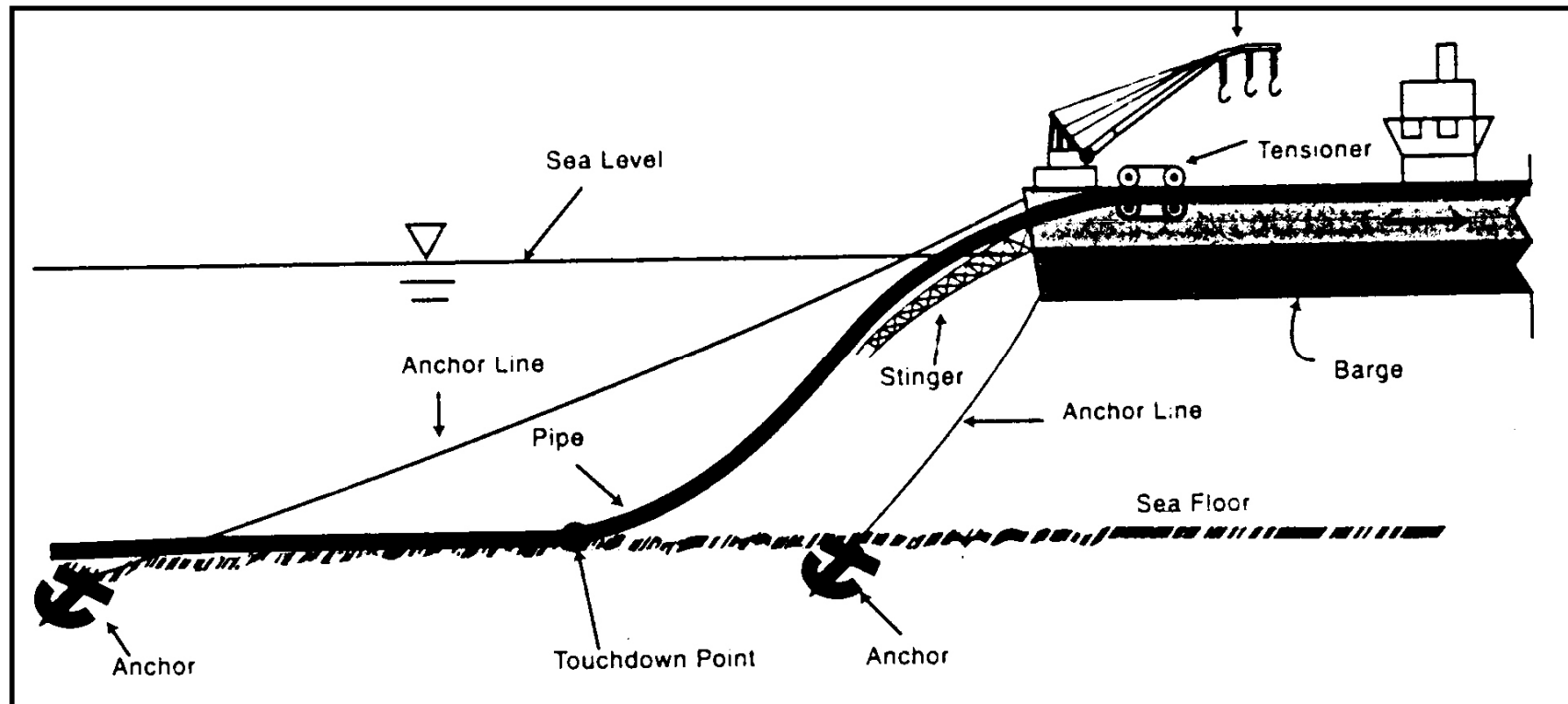

Lay barge used for laying pipe offshore and its major components

# COLD-REGION CONSTRUCTION

- In regions of extremely cold weather, such as the Arctic, or near Arctic areas, special factors and issues must be considered in the construction of pipelines
  - Freezing
  - Temperature variation
  - Environmental concerns
  - Other considerations